

# BEHIND THE BITS

A CLOSE-UP VIEW OF UAT STUDENT INNOVATIONS



BEHIND THE SCENES OF THE  
MASS EFFECT FAN FILM

TOMORROW'S TECH TODAY  
10 NEW STUDENT SIPS

KILLING  
FLOOR  
ZOMBIES AT UAT

NETWORK  
JOHN WILTBERGER  
NINJA



ISSUE FIVE

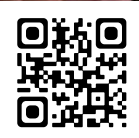





EDUCATING STUDENTS IN ADVANCING TECHNOLOGY WHO INNOVATE FOR OUR FUTURE.

**Learn. Experience. Innovate.**



# FROM THE PRESIDENT



Welcome to Behind the Bits, our student showcase of advancing technology. The work chronicled in these pages is truly impressive, creative and cutting edge. But more than that, these student projects illustrate UAT's core reason for being—to advance global society by developing premier thinkers for a lifetime of innovation.

In this publication you'll find a unique behind-the-scenes perspective that dives right into the creation and development processes, revealing the potential each student has to make a leading contribution in the constantly evolving world of advancing technology. These projects also demonstrate the power of UAT's signature Synchronic Learning model. Synchronic Learning forms the framework for a vibrant, multifaceted academic experience, which encourages students to explore new and traditional concepts, and to independently and collaboratively practice what they learn in real-world applications. These completed works embody the challenge posed to them from the day they first step foot on campus: to learn experience and innovate with advancing technology.

Fostering an environment of innovation means maintaining an atmosphere where students feel comfortable with the faculty, connected to their studies and share the same passions for new thinking as their peers. Our distinctive, private university campus helps foster this environment in which students can develop the innovative and agile thinking skills that future success in advancing technology will require.

I invite you to take a walk around our campus, where you will see groups of students working together on various technological innovations, tracking down the next breakthrough. These interactions not only challenge students to learn from each other, but also build friendships, and partnerships that will last a lifetime.

As the first computer university in the country, UAT has earned a reputation for excellence in advancing technology education. So much so that nearly one in six of our Network Security graduates went to work for a government agency in 2010. Our students are known as forward-thinking innovators and capable problem solvers.

As I reviewed these outstanding student projects, I couldn't help but be inspired myself. This work represents the essence of why this University was founded—to nurture the game changers of tomorrow to reach their potential. I hope that as you explore the pages of this issue, you are inspired as well.

Sincerely,

Jason Pistillo  
UAT President



BEHIND THE BITS

# \*CONTENTS

ISSUE FIVE

**\*06**

**CHASE SCHULTZ**  
SWEET PICKELS



**\*22**

**TECH MOMENT**

STUDENT INNOVATION TAKES FLIGHT AT COMMENCEMENT



**\*42**

**VISUAL NETWORK ANALYZER**  
JOHN FAULKNER



**SPEED OF A NINJA**

**BETTER SECURITY WITH JOHN WILTBERGER**

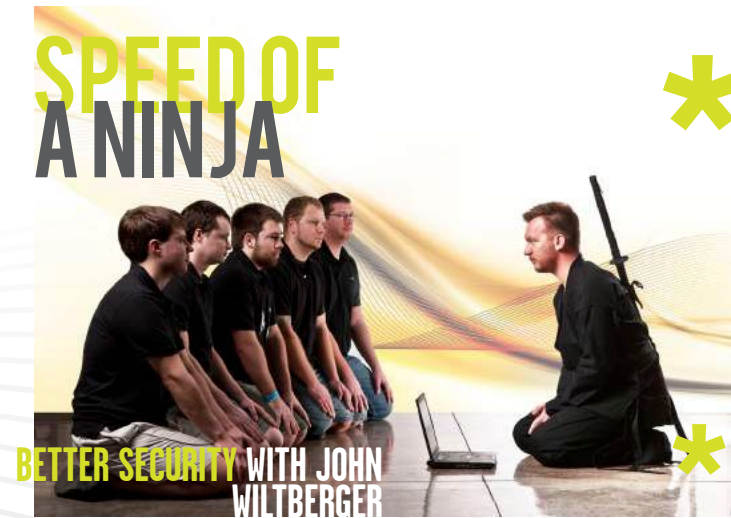

CONTENTS

**\*26**

**\*16**

**PALIO PROJECT**

UNT PROJECT TEAM TRAVELS TO WHERE OLD AND NEW WORLDS COLLIDE



STUDENT INNOVATION TAKES FLIGHT AT COMMENCEMENT

**\*32**

**UNCERTAIN**  
ROAD AHEAD  
RC CAR ON STERIODS



**\*28**

**ACCELERATED IMPACT**  
STUDENTS WIN CITY OF SURPRISE TECH CHALLENGE



**\*08**

**LOST MEDALLION**  
INCUBATING SUCCESS  
TYLER COLLEMAN  
WINSTON POWELL



**\*40**

**STEALTH RECON**  
SECURING THE WEB



**\*20**

**SECURE CELL**

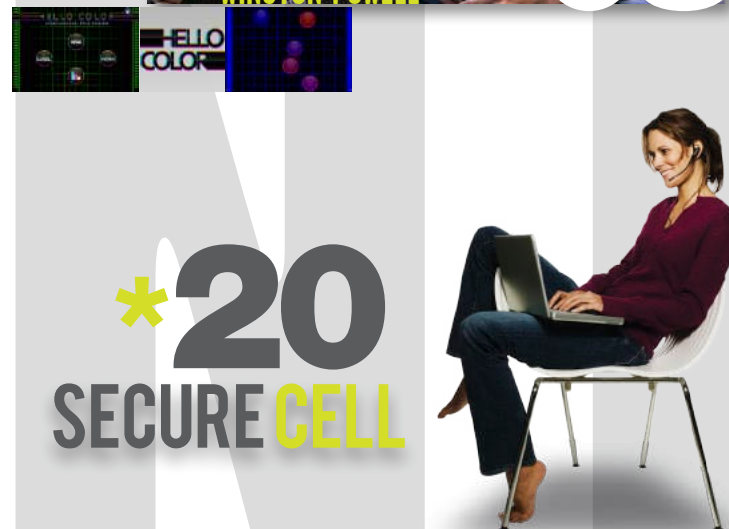

**\*44**

**KASEY NORMAN'S AFFORDABLE RECON BOT VEHICLE**

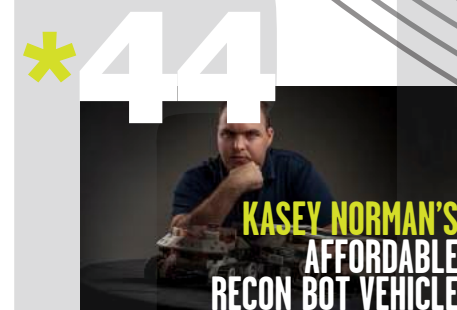

**\*36**

**KILLING FLOOR**



**\*12**

**RED SAND**

Can The Day Be Saved?

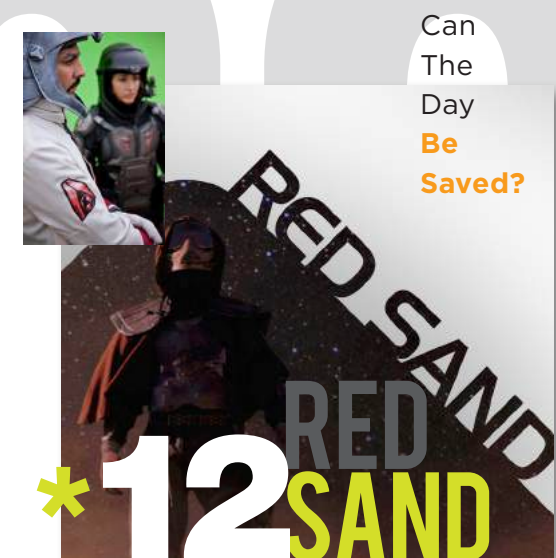

**\*49**  
SIPS



CHASE SCHULTZ

# SWEET PICKLES

## OVERVIEW

Protecting serialized pickle data in transit is what fueled Network Security major Chase Schultz to write an encryption scheme and invent open source Sweet Pickles as a student project. They're the newest way to securely transfer pickles while maintaining their functionality.

## HISTORY

It all began when Chase, a native of Goessel, Kan. who graduated in Network Security in December 2012, attended the Black Hat Conference in Las Vegas in 2010. One of the featured speakers, Computer and Net Security expert Marco Slaviero, was talking about sour pickles, those pickles that have malicious code injected into them. He mentioned there is no really solid way to make "pickling" safe. Fueled by Mr. Slaviero's talk and the environment of innovation that Chase has been immersed in at UAT, Chase was both motivated and inspired to think out of the box and try to solve a real-world security issue on his own time, apart from any class requirement. Use of strong cryptography for secret and top secret networks was an essential ingredient in his project and in his presentation last year to the DoD when he was still a student at UAT. He designed his project around these goals so that it could be used in both public and government sectors.

## DETAILS

The main idea of Chase's project was to secure python serialized objects. Imagine you have a box and take bits of paper or writing and put it into the box or a pickle. Then you encrypt the box using AES Encryption. When you create the box it's called pickling. Encryption is sweet pickling or sweet pickles.

Part of the solution lies in "Brine," a methodology that uses DoD standardized, top-secret strength encryption (AES-256). Combined with Python wrappers (software that is a bridge between an operating system and a driver) for cryptography software libraries PyCrypto and Elliptic Curve Cryptography-521, Chase is confident that only the person on the pickle's receiving end can open the file.

Chase has completed the Sweet Pickles prototype, which is functional. Aside from fine tuning it and providing written instructions for its use, it's available for free. He's hoping that the more it is accessed, the greater the chance of improving net security overall. The open source app will have a public license so anyone can access at [github.com/f47h3r/](https://github.com/f47h3r/). Click on "Repositories" and scroll down to "Brine."

Note of disclaimer: The burden of permission is on the user. If you don't have permission to use these tools, you assume full responsibility.

### Mechanics:

- > Pycrypto—encrypting of actual pickle (publicly vetted cryptography methods)
- > AES Encryption
- > PyECC—elliptic curve cryptography (public key cryptography)

## CHALLENGES

While he attended a Black Hat Conference, Chase realized the problems with secure transfer of highly sensitive information and wanted to develop a solution.

"In all reality I was looking to use some sort of secure data serialization format for the building of another project I am working on and there were not any publicly available libraries for it, so I decided to write my own," said Chase.

RSA encryption has been around since the '70s, and has been slowly weakened through the years as far as people looking into the cipher, being able to find modular inverses of the keys, etc. Slowly, people have whittled down some of the protection mechanisms that the cipher offers. Use of elliptic curve cryptography (ECC) was presented during the conference as an option.

From the time it was first theorized in 1984, ECC has not had any weaknesses found so far. DoD now uses ECC, which needs a bit



## DISCOVERIES

Chase was thinking about how to send information securely.

It was when he took an encryption theory class at UAT that he learned about how different types of cryptography work. "I was left with a really good foundation," said Chase.

He learned more about cryptography by actually applying the mathematics behind it, how a block cipher chaining works, and taking encrypted info and feeding that into the next round of encryption over and over. He also learned the technical details of how encryption works – algorithms, the math, what provides more security, what is the industry standard, who uses what, etc.

What constitutes the highest bit security you can have? While attending Toorcon one year, Chase had the chance to speak with a cryptographer who helped him learn more about the use of strong cryptography for secret and top secret networks. DoD standards mandate at least 256 bits of security for top secret information and 128 for secret information.

```
import cPickle as pickle
from CryptoWrapper import CryptoWrapper

class Brine():

    def loads(self, encryptedPickle, encryptedKey, pickleSignature,
              recipientPrivateKey, verificationKey, eccCurve, pickler=pickle):
        cryptoWrapper = CryptoWrapper()
        try:
            self.__verifyPickle__(encryptedPickle, verificationKey,
                                  eccCurve, pickleSignature)
        except:
            print 'Invalid Pickle'
            raise Exception('Pickler verification failed')
        aesKey = cryptoWrapper.eccDecrypt(recipientPrivateKey, eccCurve,
                                         encryptedKey)
        pickle = cryptoWrapper.aesDecrypt(aesKey, encryptedPickle)
        # simple integrity check to verify we got meaningful data
        assert pickle.startswith(self.picklePad), "Unexpected header"
        return pickler.loads(pickle[len(self.picklePad):])
```

size of 384 for secret level networks, and 521 bits for top secret info.

To go from 384 to 521 bits (his default was 384) meant a simple change but he had to modify the source code to do it, which presented a "bit" of a challenge.

## SUCCESSES

> Made Sweet Pickles with encryption that solved a real-world problem with under 300 lines of code so it's a simple kind of fix for a complex problem.

- > Giving back, providing a network security source code repository of resources people can easily use to ensure secure communication in a Python-based code.
- > Invited to be a guest speaker during the online workshop.
- > Demonstrated UAT's innovation and leadership by founding the [Buffer] Overflow club on campus (a UAT-sponsored information security research group), becoming a member of Student Government, a recipient of the "Student of the Month" honor and a mentor to Net Sec and Advancing Computer Science students.

## WHERE IS HE NOW?

Chase is working in Network Security for the government sector.



TYLER COLEMAN & WINSTON POWELL

# LOST MEDALLION



OFF CAMPUS  
SNOWBOWS  
JAT COMMONS

Left to right: Interns Thiago Pereira and Kendal Cormany with Tyler Coleman and Winston Powell

## OVERVIEW

It didn't take long for UAT alumni Tyler Coleman (Game Design major, May 2012) and Winston Powell (Game Art Animation major, May 2012) to be known in the big league—the motion picture industry. As founder and creative director of Retora Game Studios, Tyler and partner Winston scored a contract with Methinx Studios in California to develop video games for the movie *The Lost Medallion* released last March in theatres nationwide.

This faith-based, family, action/adventure film was created by writer/director Bill

Muir. The video games are available for download on iTunes. It also is available on Android.



The story is based on the journey of a lost medallion:

“The Adventures of Billy Stone commences as Daniel Anderson visits a foster home to drop off a donation and is quickly roped into telling the kids a story. Daniel tells the tale of Billy Stone and Allie, two 13-year-old friends who uncover a long-lost medallion and

accidentally wish themselves back in time. In order for Billy to save Allie's life, he must give up the medallion to the evil warlord, Cobra, who rules the island and its people. Now, in order to retrieve the medallion and save the island people from slavery, Billy and Allie must work together with a young arrogant king, his best friend and a wise old man. Together, this unlikely group will learn not only how to work together, but when they do, great things can be accomplished.”

## HISTORY

Tyler and Winston started Retora Game Studios with *Hello Color*, a color matching

game now available on iTunes. Since then, their jobs have grown to include contract work.

In April 2012, Tyler and Winston were referred to Muir by UAT Digital Video Professor Paul DeNigris, who met Muir at a film convention. Muir brought up the idea of making *The Lost Medallion* games and Professor DeNigris recommended Retora Game Studios. Professor DeNigris is a prime example of how well connected faculty members are in the tech industry and how those connections provide exciting opportunities for dedicated, passionate students. Tyler and Winston had a game development proposal to Muir in about

a week. They were given three months to develop two games. There was no time to waste.

## DETAILS

Although Muir provided the concept for *The Lost Medallion* (based on the movie), he gave Tyler and Winston the freedom to develop their ideas for both Medallion and the second game, *Billy's Adventure*.

These two games were developed in both iOS and Android versions and were released in spring 2013 in conjunction with the movie's release in March.

*The Lost Medallion* is a slingshot action game infused with a mini golf style game play. Can you get the gem into the medallion? The game offers 20 unique levels of game play and colorful fun for all ages. Collect the treasures to win. *Billy's Adventure* is a puzzle adventure game with the same characters and scenes from the original game going on treasure hunts. Players join Billy and friends as he adventures through 10 levels. Using his trusty set of tools, Billy must find his way through the jungle to find the lost medallion.



# TYLER COLEMAN WINSTON POWELL &

## PLAY TESTING

To make sure all aspects of the games were ready for the big launch, Tyler and Winston conducted two play tests, 10 days apart, each during a two-hour time frame with kids ranging in age from 4-16 and their parents. The information they gathered during the first play test was incorporated into the second play test.

Tyler and Winston, who had early exposure to technology when they were kids, were amazed at what an early age kids develop an aptitude for games and technology and how advanced the kids' skill levels were—even at age four. Tyler referred to what Malcomb Gladwell, author of the bestseller *The Tipping Point*, said, that "10,000 hours of video gaming is the tipping point at which time you become an 'expert.' At this rate, by the time they [kids] get to high school the average student will reach 10,000 hours even if they only play two hours of video games a day."

The play tests were eye-opening experiences that helped both he and Winston ensure the games fully reflect young gamers' capabilities.

## CHALLENGES

Contract work was new to Tyler and Winston. "As contracts go, we didn't get the right experience because Bill gave us lots of freedom to develop the games," says Tyler. "It wasn't a true contract experience in that we didn't have lots of guidelines and stipulations, although it was very rewarding and exciting."

## SUCCESSSES

- > The play tests were eye openers and, according to Tyler, "definitely a curve ball learning experience, and really successful."
- > Developing these games was a lot of fun and gave them the ability to develop other projects for others as a company.
- > Tyler and Winston were given the freedom to take their game development in their own direction. This demonstrates Retora's capabilities not only to Wethinx but also to future, prospective clients.

## WHERE ARE THEY NOW?

Tyler and Winston graduated in May 2012 and are growing their company, Retora Game Studios, often utilizing the commons at UAT to complete their work.

Retora is an independent game production company specializing in full service game and mobile app development, including individualized art and design services.

Tyler focuses on marketing, business development and game programming. Winston focuses on the various aspects of game art and web design, including animation in both 2D and 3D, After Effects and Word Press.



Tyler Coleman with provost Dave Bolman

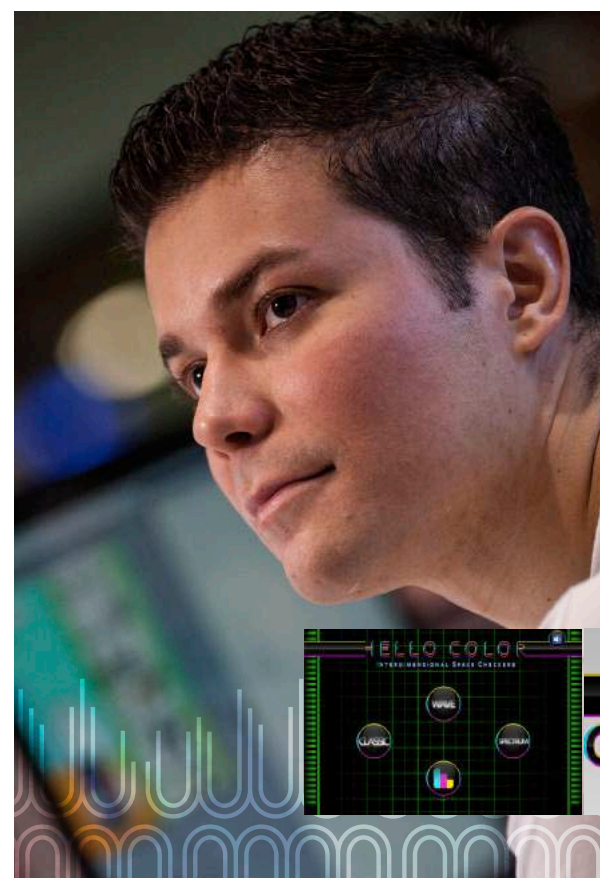



The stakes are high. A band of terrorists is threatening the sanctity of Mars' ancient ruins: an exploration of the future of galaxy exploration.

# RED SAND

## OVERVIEW

Before Mordin there was Averroes. Before Ashley there was Sandhurst. Before Shepard there was Grissom. Before the Mass Effect video game trilogy, there was—and is—

*Red Sand: A Mass Effect Fan Film.*

This online fan film was created by UAT film students as a prequel to the Mass Effect video game trilogy. The film was written and directed by UAT senior Caleb Evans, produced by Professor Paul DeNigris and includes a crew of 15 and a cast of nine. Guest star is Mark Meer, actor, writer and improviser who is best known for his roles in 2007's *Mass Effect* and its sequels, 2010's *Mass Effect 2* and 2012's *Mass Effect 3*, in which he stars as the voice of the male version of the player character, Commander Shepard.

"We may do some sort of convention run, and bring our star to a convention and talk about it," says Professor DeNigris, who also served as VFX Supervisor and Faculty Advisor for the film.

Although many fan films (film or video created by fans and inspired by a film television program, comic book or similar source) for *Mass Effect* are in existence, few, if any, are prequels.

The setting for *Red Sand* is 35 years before the time of Commander Shepard, when ancient ruins were discovered on Mars. The ruins were left behind by the mysterious alien race known as the Protheans, and represent a treasure trove of advanced technology and the powerful Element Zero, an energy source beyond humanity's wildest dreams. As the Alliance research team led by Dr. Averroes (Ayman Samman) seeks to unlock the secrets of the ruins, a band of marauders living in the deserts of Mars wants the ruins for themselves. Addicted to refined Element Zero in the form of a narcotic nicknamed "Red Sand" which gives them telekinetic "biotic" powers, these desert-dwelling terrorists will stop at nothing to control the ruins and the rich vein of Element Zero at its core. Standing between them and their goal are Colonel Jon Grissom (Mark Meer), Colonel Lily Sandhurst (Amy Searcy), and a team of Alliance soldiers tasked with defending the ruins at all costs. At stake—the future of humanity's exploration of the galaxy, and the set up for the *Mass Effect* storyline loved by millions of gamers worldwide.

## HISTORY

As Caleb thinks back on his school career, he never thought he'd get to make a movie based on a franchise as incredible as *Mass Effect*. In fact, when the Madbury, NH, native first arrived at UAT he was enrolled in a different major altogether. He switched from Game Design to Digital Video and discovered an exciting new world.

"I had always loved film, and knew it was what I wanted and needed to do when I took Paul DeNigris' DVA101. UAT gave me the privilege to meet and work with some of the best people I have ever known in my entire life. I am a better person because of this school."

When the time came to decide what to make a film about, he and his Digital Video classmates played around with several ideas, but as soon as he said *Mass Effect*, the entire class was behind the idea.

"That momentum and excitement snowballed into an extremely dedicated group that made an incredible film," he says.

Just how did UAT get a star as big as Mark to participate? Professor DeNigris asked him. He sent him a cold email, to which Mark responded enthusiastically.

"Mark was very supportive of the project from the get go," explains Professor DeNigris, a star in his own right as an award winning film maker and film educator. "He read the script and saw the strength of it, and that's what hooked him. And then he saw *Fallout* and a few of the other UAT films and was even more impressed."

Professor DeNigris opted for more of a supervisory position (as producer) in this film project to give students more of the hands-on experience. He worked with student Samantha Hammond. "Our job was to make sure Caleb had all he needed to tell his story," says Professor DeNigris.

Here's a fun piece of trivia: Professor DeNigris wasn't personally a fan of the *Mass Effect* series when the project began—but he is now. The power of the script and the passion of the students converted him into a big fan. After studying the trilogy with his students, he discovered what a tremendous piece of video game art *Mass Effect* truly is.



# CAN THE DAY BE SAVED?

## DETAILS

Production included the 10-minute short film, a teaser trailer and an action trailer. Pre-production began in fall 2011, and the shoot began in January 2012. The teaser trailer was completed in February, and the film was posted to YouTube in October.

The film was shot all in daylight to capture the effects of nighttime on Mars. They used the sun as their main light source and were able to make it appear like nighttime in the camera.

Among the high tech equipment used by UAT's Digital Video production

students and faculty in the making of Red Sand:

### Production:

- > Canon 5D / 7D DSLR's for shooting 1080p HD Video
- > Redrock Micro DSLR Support Cage / Mattebox / Follow-Focus
- > Manfrotto Carbon Fiber Tripods
- > Dana Dolly Camera Slider
- > Tascam Digital Audio Recorder
- > Wireless Lavalier Microphones
- > 12x12 Greenscreen
- > 5x8 Collapsible Greenscreens
- > UAT Greenscreen Stage
- > Arri 650 Lights
- > Arri 1K Lights
- > C-Stands, Flags, Appleboxes, and other industry standard grip equipment

### Post-Production:

- > Avid Media Composer (editing)
- > DigiDesign ProTools (audio)
- > Adobe Photoshop (matte paintings & textures)
- > Adobe After Effects (compositing & rotoscoping)
  - > Autodesk Maya (modeling and rendering)
  - > Z-Brush (modeling)
  - > Mocha (planar tracking & rotoscoping)

## CHALLENGES

For Caleb, deciding what the story would be was a huge challenge. He wanted to be true to the universe yet have some freedom to make it his vision. He adds that directing a film is stressful and exciting all at the same time.

"I feel the pressure from my peers and school, not only that, I feel the weight of the entire *Mass Effect* community on my back. Because if I mess up one phrase or misuse one part of the universe in any way it will be picked out and criticized. That's why I tried my hardest through hours upon hours of work to create a new section of the *Mass Effect* universe that has not been fully explored, while giving the audience an exciting movie that they will want to see."

But the biggest challenge for Caleb was to get the film known to a wide audience. Getting the film out and featured on websites is the hard part, getting the right person to see it.

"We all want, and I really want, nothing more than to share this with everyone; this film is for the fans," says Caleb. "We want them to love the film as much as we do."

According to Professor DeNigris, there were challenges with sheer number of visual effects, either in space (starship) or on Mars. Managing a team and work flow were a challenge too just because of the great number of visual effects shots that totaled between 400 and 500 because of Mars' open, expansive, polar region and alien ruins.

## SUCCESSSES

There was so much excitement for this prequel because of the tremendous interest in *Mass Effect*. A teaser was posted on the UAT site in February 2012 and got 95,000 views. The film launched on YouTube in October that year and by year's end had more than 150,000 views in four months, well over the expected 100,000 goal.

"For me as professor, the most rewarding part is when I see a group of students come together as a team," says Professor DeNigris. "Students took the lead—instructing, taking responsibility and working like professionals. This was a great accomplishment."

## WHERE ARE THEY NOW?

### Director

Caleb Evans—Class of 2012

Caleb graduated in 2012 and currently is a Curriculum Videographer for UAT.

### Co-Producer, Composer

Samantha Hammond—Class of 2012

### Director of Photography, Composer, Body Double

Jared Oppie—Class of 2012

### Art Director

Ariel Navarrete—Class of 2012

She currently is a graphic artist at Liberman Broadcasting in Los Angeles, Calif.

### 1st AD, Lead Prop Design, Composer

Jamil M. Abubakar—Class of 2013

### Editor

Paul Rosario—Class of 2013

### Key Grip, 3D Modeler, Composer, VFX Coordinator

Ib Gillett—Class of 2013

He is a senior majoring in Game Art & Animation and Digital Video. He currently works at Stitch and Print Technology.

### Make-up Special Effects artist, composer, a Marauder

Alyssa Mann—Class of 2012

### Sound recorder and designer

Erica Faccione—Class of 2012

Erica graduated in Digital Video and is working as Lead Editor at Arizona Virtual Studios.

### 1st AC, Composer

Dylan White—Class of 2013

Dylan currently is a senior majoring in Digital Video.

### Camera Assistant, Composer

Annie Winn—Class of 2012

Annie graduated in Digital Video and is working with UAT's Digital Video program at UAT to create two more short films: *Ouroboros* and *Borderlands* fan film. She currently is looking for a job in Los Angeles, Calif., preferably with a film production company or a visual effects company.

### Grip, Composer

Neil Keith Sparks—Class of 2014

### Grip, Composer

Tyler Bitterolf—Class of 2013

### 3D Artist, Composer

Alicia Preston—Class of 2012

Alicia is currently is working for AT&T providing technical support.

## CREW

- Director  
Caleb Evans—Class of 2012
- Producer  
Paul DeNigris
- Producer, Composer  
Samantha Hammond—Class of 2012
- Director of Photography, Composer, Body Double  
Jared Oppie—Class of 2012
- Art Director  
Ariel Navarrete—Class of 2012
- 1st Assistant Director, Lead Prop Design, Composer  
Jamil M. Abubakar—Class of 2013
- Editor  
Paul Rosario—Class of 2013
- Key Grip, 3D Modeler, Composer, VFX Coordinator  
Ib Gillett—Class of 2013
- Make-up Special Effects Artist, Composer a Marauder  
Alyssa Mann—Class of 2012
- Sound Recorder, Designer  
Erica Faccione—Class of 2012
- 1st Assistant Camera, Composer  
Dylan White—Class of 2013
- 2nd Assistant Camera, Composer  
Annie Winn—Class of 2012
- Grip, Composer  
Neil Keith Sparks—Class of 2014
- Grip, Composer  
Tyler Bitterolf—Class of 2013
- 3D Artist, Composer  
Alicia Preston—Class of 2012
- 3D Artist, Composer, Grip  
Zachary Robinson
- CG Modeler  
Elissa Clare
- Technical Artist  
Dennis Porter
- Concept Artist  
Sayla Barnes
- Senior Composer, Grip  
Trevor Spotted Eagle
- CG Modeler  
Tyler Felton

## CAST

- Mark Meer as "Colonel Jon Grissom"
- Ayman Samman as "Dr. Averroes"
- Amy Searcy as "Colonel Lily Sandhurst"
- Greg Bronson as "Red Sand Leader"
- Shane Dean as "Jenkins"
- Jeffery Lamar as "Hido"
- Will Leon as "Erickson"
- Jeff Houkal as "Lee"

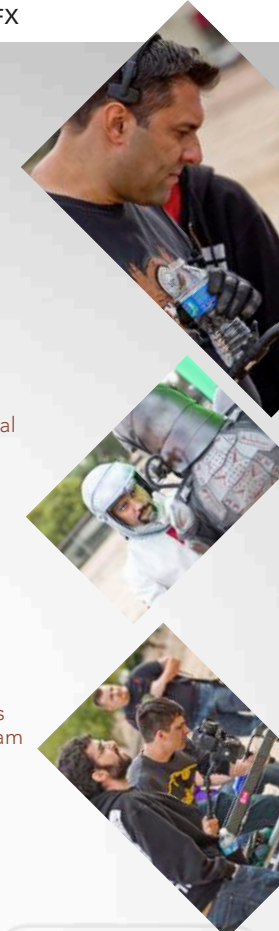



PALIO DI SIENA

RACE

# THE palio project

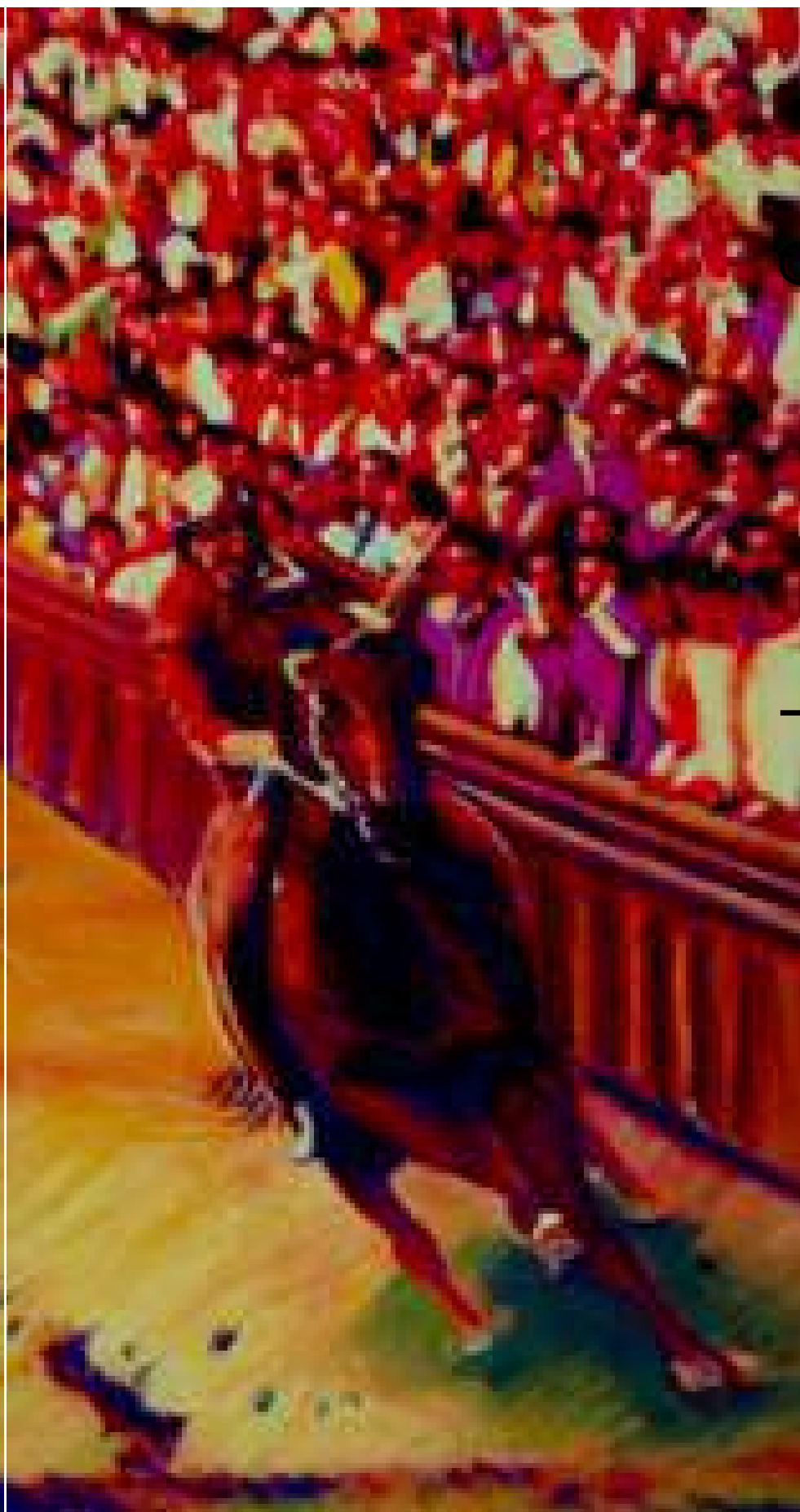

racinq from the past to the future



# THE PALIO PROJECT

# UAT project team travels to where old and new worlds collide.

## OVERVIEW

For 19 UAT students, UAT's Learn. Experience. Innovate focus can be summed up in three words: *The Palio Project*. They are recreating a horse race in a unique game, but not just any horse race, the Palio di Siena horse race in Siena, Italy, that dates back to the Italian Renaissance. Seven students traveled to Siena last summer 2012 to attend the race, accompanied by Professor Paul Andres and Professor Lynn Understiller.

This 13-day trip from June 26 through July 9 gave the opportunity of a lifetime to students to experience the race July 2, the pre-race's Corteo Storico pageant, and all the pomp and circumstance in the days prior to the event. The opening of the race with the pageant took four hours. The race itself took 90 seconds. The research to get it just right and represent the full splendor of this fiercely proud tradition in a game has taken months.

Today's Palio di Siena race consists of horses and riders dressed in their respective colors to represent nine of the original seventeen contrade, or city wards. Jockeys ride bareback and sometimes are thrown from their horses as a result of the treacherous course, high speeds and competitive spirit. They're on an unfamiliar horse, racing against bitter rivals who will do practically anything to win. The race circles the Piazza del Campo three times and requires luck, skill, focus and determination from each player. Anything goes! In the blink of an eye, a jockey will either bring glory to the family or fall to another.

## HISTORY

Steeped in more than 600 years of history dating back to the Italian Renaissance in 1581, the Palio di Siena is the world's oldest annual horserace and also considered the most dangerous. Tickets are at a premium and sell out months in advance.

Seeing the Palio is a life-long goal among many people in Italy and beyond. The next best thing to going to the actual race itself is playing the game.

The idea for the trip was spawned by Professor Paul Andres, who is dedicated to giving his students a

broader outlook on life and an unforgettable experience along the way.

## DETAILS

The game was developed using the Unity engine. Artists created 3D models in Maya and the horse and jockey details in ZBrush. The project was managed using the online tool Assembla which also saves their code. They've kept most of their documents in order with Google Docs.

It was important to the team that the Palio's culture, with its rich colors and energy, be accurately reflected in the game. No drab browns and grays were used in the art design so that every bit of color and vibrancy that each contrada contributes can be represented to create an almost storybook ambiance.

## HOW TO PLAY

Players choose one of the seventeen Contrade or families to race. They begin as the solo horse and jockey behind the starting line while the remaining eight horses and jockeys vie for position at the starting line. When the player is ready, they begin the race by passing a rope which drops the starting line for the rest of the horses. The player controls the horse with the arrow keys or WASD and can whip their horse for a speed boost by clicking the left mouse button. They can also kick the other horses by moving the mouse to the left or right and clicking the right mouse button. If they successfully kick at the right time, they have a chance to knock the jockey off the horse. The race ends after the first horse (even without their jockey) passes the finish line after three laps.

Players are given a lot of freedom as to how they want to run the race. You can be as sportsmanlike as you'd like... or play dirty; you can try to push your rivals into the wall or knock them from their horse, but don't expect them to play fair either.

In the game, jockeys are being engineered for independent movement. While riding, they can whip their own horses or ones adjacent. They can also kick other jockeys to knock them off balance, but during the kick they can be knocked off themselves because stability

is jeopardized. If a jockey becomes dislodged, the player loses all abilities associated with the jockey while the horse gains speed due to weight loss.

## CHALLENGES

UAT senior Chris Jennewin, project manager, and the team have overcome a number of challenges in their first three semesters working on the game:

> For many of the team members, this was their first cross-department project, so they had to learn how to work with other areas and pass their work onto the next group in the development pipeline. This held true for Chris, who had to learn to work with 3D artists and take the time to understand their processes.

> Communicating at a distance. When half the team went to Italy last summer, they did not have the internet connection they planned. They were only able to set up two meetings in two weeks. The Italy team experienced difficulties getting to email every day, so communication was slow. The team back in Tempe experienced a pipeline issue and had to make a decision without much discussion from half the team. In the end, it wasn't a major setback, but proved difficult in the heat of the moment.

## SUCCESSSES

> The amount of knowledge the team gained was "definitely the high point of this project," according to Chris. They have been supported by so many people at UAT that they all feel encouraged to make this the best game to come out of the school so far. Chris can't say enough about what they've learned. He picked up some 3D modeling skills and can navigate Maya more easily.

> One of the hurdles Team Palio cleared was the slow progress seen by those outside the team. The team gave at least two presentations on the game to the school without much working content. This could have been viewed as a lack of work, but that was not the case. Since many of the team members have graduated or moved off the project, it has taken more time to integrate work from all departments. But by the December presentation to UAT staff and faculty, they had a really nice beta build that showed the game completely running with only a few features missing. "The reception was great and I think we stifled any doubt concerning our progress," Chris said.

They polished their beta in time for the GDC Pitches on January 22, and feel fortunate to have passed UAT's new



The team took this small indie game to the annual Game Developer's Conference (GDC) in March 2013 to demonstrate the full extent of UAT's technology capabilities. There are no immediate plans to market the game.

Greenlight process that allowed them one more semester of production. Release is scheduled in phases, initially to their Kickstarter backers in February followed by the GDC introduction March 25-29. April will be devoted to PR and Marketing and reviewing their options for distribution. The Palio game should be available for download in May if they can remain on schedule.

Because funds were needed to support this scale of project and also trip expenses, both faculty and students pulled together to create fundraising opportunities. Professor Andres created a painting of The Palio to auction off. Alumnus Tyler Coleman spearheaded a fundraising effort through the Kickstarter program (kickstarter.com) that helps small groups and starter companies raise money. A total of 108 people from all over the country donated, generating more than \$10,431.

Among the expressions of appreciation were a signature Palio t-shirt, a digital painting and 3D models of the horse and jockey, hand-painted in the colors of a Contrade.

## WHERE ARE THEY NOW?

- TEAM PALIO**
- Chad Armstrong - Game Designer
  - Adam Beck - Asst. Art Lead
  - Andrew Bortniak - Artist
  - Colt Buhr - Game Design Lead
  - Mario Castaneda - Art Lead
  - Tyler Coleman - Marketing
  - Alex Dinh - Game Programmer
  - Erica Faccione - Digital Videographer
  - Anthony Guilkey - Artist
  - Brian Hartong - Game Programmer
  - Chase Henderson - Animation Artist
  - Jonathan Jansma - Game Scripter
  - Christopher Jennewein - Project Manager
  - Joshua Kelly - Artist
  - Claire Leighton - Asst. Game Design Lead
  - Lucas Mateyko - Game Programmer Lead
  - Adam Moore - Game Programmer
  - Devon O'Mara - Artist
  - Jessica Zellner - Artist



SECURE CELL NETWORK RIVAL

# BIG CARRIERS



"I was glad to have the opportunity to participate in ICDW, and thrilled that people were excited to hear about this new network."

## OVERVIEW

The cellular networks we're familiar with are the major names we recognize—Verizon, AT&T, T-Mobile, Sprint, etc. Now, there's one that serves as a more cost effective and secure alternative for cell phone use: Drew Porter's Open GSM, a cellular network that was his Student Innovation Project (SIP). GSM stands for Global System for Mobile communications.

The Open GSM can be installed and operated at about 1/10 the cost of current technologies (1,000th of a cent per minute), but still will be compatible with most handsets already in the market.

Drew's network is more secure, calls are less expensive and there's a small cellular network option for businesses and third world countries that otherwise may not have access.

## HISTORY

"Originally, my project involved just doing a reversing of GSM networks and finding vulnerabilities within the current GSM network that I was going to fix," says Drew, who graduated in spring 2012. "And then I was thinking well, if I'm going to find them and fix them, why don't I just develop a GSM network that is spec-compliant and secure right off the bat."

## DETAILS

"Typically, the major cellular networks connect on the front end, which means they focus on what you can see, namely the cell phone itself, its use and connection to the cell tower," says Drew. "Mine focuses on taking the call from the tower to everything in the back end, which is where all the technology connects together—everything people don't see that makes it all work."

Drew's prototype is an open source back-end GSM network that:

- > runs off a laptop
- > works via the internet
- > uses a portable USRP "cell tower" that can fit in a backpack
- > connects to an existing handset, or phone from a GSM network, such as AT&T or T-Mobile

## FUTURE

Drew's work to refine this project will be ongoing—possibly throughout his lifetime. Development is broken down into three phases:

- > Phase 1: Completed. Working prototype was developed; database and network expandable. Two cell sites were established to communicate to a central MySQL database.
- > Phase 2: In Progress. Spec Compliance will be involved in this phase to become more of an actual GSM backend that integrates current practices by cellular communication companies into the open source project—to creating a more open community within cellular networks.

With this phase, there will be an HLR, VLR, EIR and an AuC database (they can all be part of the same physical box). The first step is to get the HLR, VLR, and EIR databases up and configuring everything so that each asterisk box can route the calls, even if the numbers are in a different databases than the one



accessed (DB Table 1, DB Table 2, etc). Also having the TMSI being sent to the VLR and updating the HLR is part of the project.

- > Phase 3: Plan. Get SIGTRAN working as a control mechanism for the transferring of calls to integrate them with multiple "carriers" and establish seamless communication.

"My project is accessible to everyone and I encourage their review, testing and feedback from other people," says Drew, emphasizing it is a living, breathing project that will evolve throughout his lifetime. "The whole point of open source is that many eyes make a better project."

Because Drew's Open GSM is an open source network, he encourages anyone to visit GitHub.com and try it out: <https://github.com/iamredshift/OpenGSM/wiki/OpenGSM>

## CHALLENGES

Drew had to figure out how to get the base software working (open BTS—front end). His combination of hardware did not provide any direct "how to" nor any example of people doing it. He used the USRP N210 with the SBX Daughterboard, which is the actual radio interface side.



People have done it with the USRP N210 but not with the SBX Daughterboard.

## SUCCESSSES

Drew was one of five Network Security students invited to present at ICDW because of the innovative nature of his SIP. His previous conference experience really came in handy. During a recent ToorCon conference, he presented a talk on how cellular networks communicate. "I was glad to have the opportunity to participate in ICDW, and thrilled that people were excited to hear about this new network," says Drew, who added "It was a great experience." He was recognized by the DoD in a congratulatory letter.

## WHERE IS HE NOW?

Drew currently works as a Mobile Security Exploit Engineer for Cummings Engineering.

"The Open GSM project is based off the Open BTS—UHD project but more off a traditional GSM network. Where Open BTS uses Asterisk for an EIR and HLR, the Open GSM project used MySQL database to act as a more traditional EIR and HLR. This also means that the Open GSM project will allow for a VLR if multiple databases are used. With this, each Asterisk server will have to be aware of the other (like one would do already in extensions.conf)."



## STUDENT INNOVATION TAKES FLIGHT

## AT COMMENCEMENT

## OVERVIEW

In spring 2012, about 200 UAT graduates experienced a unique commencement tradition that, in addition to the motivational speeches and presentation of diplomas, demonstrated once again just how innovative these future tech leaders really are.

Quite possibly the only project like it in Arizona, Tech Moment is a unique, interactive technology project developed by a select team of UAT students that actually takes place during commencement. As a 10-minute portion of the commencement, Tech Moment is intended to be a surprise for graduates, who look forward to its unveiling every year. The project showcases innovation and the spirit of collaboration, two key areas of learning and growth at UAT.

This year's project involved graduates wearing LED badges that prompted each graduate to do the Wave and navigate Lite Flight, a crowd-controlled video game using computer vision software which tracked the badges and allowed graduates to collectively control a flight simulator.

Representing four specialty areas/degree programs including Robotics and Embedded Systems, Advancing Computer Science, Game Design and Game Programming, team members included Professor Ryan Meuth (Robotics and Embedded Systems), Professor James Justin (Game Programming), Professor Phill Miller (Computer Programming), and students Kasey Norman, Colt Buhr, Lester Dominguez, Pralie Dutzel, Jacob Hoffman and Stacy Layton.

## TECH moment

## HISTORY

The project took nine months—from August 2011 through Spring 2012—and finished just in time for commencement. Great planning and time management provided ideal timing and meant no last minute rush. Without the full range of resources available to UAT students on campus, this would not have been possible given the relatively short time frame.

Early on, the team knew they wanted to come up with an interactive, immersive idea for the graduates that connected to UAT's mission and reflected the essence of what a UAT education offers to each student. This idea not only seemed to fit but also seemed to be the most exciting and deliver the biggest impact.

The team started brainstorming ideas, focusing on crowd involvement, and enhancing the atmosphere of the event. They chose the LED badge idea over others because it was the best of all the ideas (others were RFID name cards, Word Cloud, and Reactive Lighting). Some ended up being too complex and others too simple. The plane idea worked best with the RFID and the level design was easy to create with the Unity 3D engine.

## DETAILS

The team of six students and three faculty members built everything from scratch.

The Wave was introduced first to the audience. Graduates were asked to join in when their badges lit up. A dotted ripple of lights moved from one end of the room to the other in a synchronized pattern.

Lite Flight followed. As a webcam tracked their movements, graduates worked together to navigate, with their bodies, a virtual airplane on a screen. They swayed left and right to steer, snag virtual coins and avoid crashing into the canyon wall or river below.

Because the game was written using the Unity game engine, which was very different than Python, the two programs communicated over a network connection.

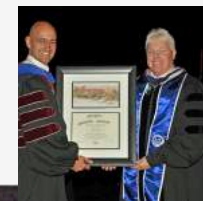



COMMENCEMENT AUDIENCE

# DOES DIGITAL WAVE

# TECHmoment

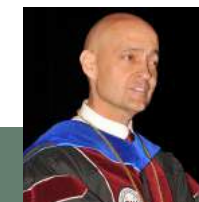

## DEVELOPMENT STAGES

**August 2011**—Focused on crowd involvement and brainstormed ideas, including LED Badges, RFID name cards, Word Cloud and Reactive Lighting.

**September-December 2011**—LED badge concept, prototype development began.

**January 2012**—Professor James Justin's Experimental Games course was formed to develop an interactive game with the badges. Professor Ryan Meuth's students wrote the master-control firmware, which runs on Arduino, to translate messages into a series of infrared light pulses the badges could interpret.

**February 2012**—The team designed software for a webcam and computer vision techniques to track badge locations using open-source software such as OpenCV and the Python programming language.

**March 2012**—The entire system was demonstrated for the first time to a small group of staff and administrators.

**April 2012**—All production badges were built using a toaster oven to solder surface mount parts. Final debugging and tweaking was performed on their software before presenting at Commencement 2012.

## CHALLENGES

> "I learned that Unity 3D doesn't like it when you have Pro material in the Free version," Colt says. "It tends to vomit all over itself and cause a LOT of problems. However, it was easily fixed but lesson learned on that one."

> Respawn mode set improperly, which made the airplane dive straight into the wall five times. "Running into the wall five times was funny but obviously a mistake on our part," reflects Colt. "It should have been placed toward the open area and allowed the player to continue playing. I had a good laugh when I realized it though as it was something that was easy to fix but simple to miss. One of those 'oops' moments, but everyone had fun with it anyways so I don't have much to be disappointed about."

> The firmware (program running on the microcontroller on each badge) was really challenging, because we had to ensure the master computer could communicate reliably with the badges at a range of approximately 100 feet using pulses of infrared light, similar to what your TV remote control uses to communicate with your television," explains Professor Meuth. "The messages sent to the badges commanded them to change color or turn their LEDs on or off. Since we were using microcontrollers donated by Microchip Technology, we used their new software development environment, MPLAB X, to develop and debug the firmware."

## SUCSESSES

> The way the team approached the project added to its success—a traditional yet informal development process. The team approached the project in a collaborative, constructive, research based manner that helped them set their goals and met them. It wasn't just the instructors telling the students what to do. It truly was a collaborative process where everyone pitched in and worked hard like they would in any academic research project.

> The fact that no one had to stay up and pull an all-nighter before commencement demonstrates how well the planning process went and how well they managed their time. "This is a big accomplishment for students and very impressive," praises Professor Meuth.

> "What I liked most about the team was that we all came together to make something in such a short time frame (one month) and got it to work correctly with the RFIDs the first time," says Colt Buhr, level designer for the project.

## FUTURE

Because of its innovation, this year's project also is educating others beyond UAT at tech fairs and conventions, already appearing in spring 2012 at the Maker Fair in San Diego and Comicon in Phoenix.

To watch the Tech Moment in action, visit [uat.edu/techmoment](http://uat.edu/techmoment)



## WHERE ARE THEY NOW?

**COLT BUHR**  
Major: GAME DESIGN  
2012 GRADUATE

**KASEY NORMAN**  
Major: ROBOTICS AND EMBEDDED SYSTEMS  
JUNIOR

Once Kasey completes his undergraduate degree, he wants to continue on to complete his master's degree and hopes to enter the medical robotics field—robotics that can assist the elderly maintain independence.

Kasey is a full-time student and a full-time employee in Phoenix as a Surface Mount Technology Technician. (His portfolio that included Tech Moment helped him get the job!) He's volunteered in the past to help students at Coronado High School with their after-school robotics program and is hoping he'll find time again to help with the FIRST® Robotics Competition Arizona Regional.

**LESTER DOMINGUEZ**  
Major: GAME DESIGN  
2012 GRADUATE

Lester currently is working as a Game Designer at Ten Thousand Tales Games, a Game Designer at Super Fun Games and as a Collections Co-Worker at Rent-A-Center.

**JACOB HOFFMAN**  
Major: COMPUTER SCIENCE  
2012 GRADUATE

**STACY LAYTON**  
Major: GAME PROGRAMMING  
SENIOR

While attending school, Stacy is a Game Programming intern at Nullspace Entertainment, LLC.

**PRALIE DUTZEL**  
Major: GAME DESIGN  
2012 GRADUATE

Pralie currently is working as a game designer at Katastrophe Games.



# BETTER SECURITY WITH THE SPEED OF A NINJA



## OVERVIEW

The integration of information online is happening at the speed of a Ninja, and so is the need to secure it. But keeping track of all the security tools out there, knowing what to access and how to use them to attack and defend against threats can be more than a little daunting.

Network Security and Network Engineering double majors John Wiltberger, project lead, and co-author William D. Howe devoted their joint Student Innovation Project (SIP) to developing Network Ninja. This security training tool harnesses the real world's vast array and complexity of programs and suites in an online, one-stop shop to help Network Security students, and information security and assurance newcomers, learn step by step.

Network Ninja is a virtual, self-contained testing environment. This unique program teaches the basics of security tools and Linux operating system software that allows those with nearly no Linux experience the ability to become masters. The virtual environment simulates using software like Nmap and THC-Hydra.

Like a ninja, Network Ninja provides the tools to attack and thwart network vulnerabilities with precision, helps users master techniques along the way and advance to different training levels. The goal of the project was to have a true "single download" operating system in which you could start learning some network security content, without having to setup the entire environment on your own (sort of the "first step," before learning something more intermediate/advanced such as Backtrack Linux).

"The first time we actually pictured this project, we were told it was impossible," John says. "We had so many big ideas. A lot of times people have problems with their SIPs for this very reason. We wanted it to be easy to use and provide virtualization."

He credits UAT's teaching style for his progress with his SIP. Because technology changes so rapidly, they do more than just teach the technology; they help you grasp the concept and learn how to stay on the cutting edge while providing hands-on experience. "This environment prepares you to adapt quickly to changes and stay ahead of the curve," John says. That's just one of the reasons John left his pursuit of a business degree at a large public university to come to UAT. "I realized I liked computer stuff. I've learned so much here."

## DETAILS

John and William split development of the tutorial content down the middle. They collaborated on the web page with two other students who developed the initial web page skeleton template (Patrick Pinder, Network Security/Network Engineering major, Spring 2012), Network Ninja logo (Christopher Salat, Network Security/Game Design double major, spring 2012) and other elements of the program.

Initially, John's job was to build the distribution Linux from scratch. He

also created the network and virtual integration for the Live CD. After playing around with several building utilities, including Linux From Scratch (LFS), he built the Linux environment through a script called Remastersys once he stripped down an original Ubuntu 10.04 distribution. He then designed the virtual network inside the project using VirtualBox to avoid licensing restrictions enforced by the more popular VMware product line. Next, he created some of the tutorials outlined on the website hosted inside the project.

He credits UAT's teaching style for his progress in his SIP. A 2011 graduate from Plymouth, Minn., William built the programming for the website, some of the tutorials as well as the customized Python Testing Engine to help promote hands-on training of the tools. This interactive test engine was a custom program he wrote in Python to provide a more interactive way to learn command line network security programs. William then downloaded each individual package for the kernel of the computer operating system and all the modules that go into the kernel.

William didn't know Python before that, but he learned by being immersed in a real-world situation where you figure it out and just do it. UAT is well respected for giving students the tools necessary to find solutions, problem solve and create tomorrow's innovations.

Throughout his UAT experience, William feels the Network Security professors do an outstanding job of supporting their students. "There are always a lot of projects that promote self learning/discovery in addition to what is taught in class, which is extremely important in the Network Security/Engineering field."

## HOW THE PROGRAM WORKS:

- > When you launch the program, it brings you to the main menu.
- > From there, you enter in a security program (that coincides with the tutorial content chapters).

- > It asks you questions on how you would perform a certain action with that program and prompts you for an answer.
- > The program lets you do manual page lookups right within the question. Once you enter a possible answer:
- > If it is incorrect, you are told to try again and hinted to look up the command in the manual page/check syntax.
- > If it is correct, the command is actually sent to the operating system, run, and the command output is displayed.

## CHALLENGES

- > John faced challenges compiling a distribution without a compiler, which is needed to take the instructions in source code and turn it into 1s and 0s.
- > John and William were up all night trying to figure out how it was going to work. John was saying "I don't know how we are going to do this" when William said "How about we try Linux from scratch?" John went to Walmart in the middle of the night and bought a jump drive. William built the programming and the entire kernel was transferred to the jump drive. Then it happened. Just hours after they finished someone accidentally bumped the computer where the jump drive was connected and it fell out and broke apart.

## SUCCESSES

- > Getting that first project off the ground with their first plan of action, and creating a live CD, was a big accomplishment.
- > "Hindsight is 20/20," John says. "It was actually a really good thing the student damaged our USB drive because we learned afterward that Linux from scratch is not the best. This accident gave me the opportunity to stop and say to myself: 'You did it once, you can make it again, you've learned a lot.'" UAT helped him to realize that. William actually learned Python to complete this project, so there was plenty of debugging/research to figure out the best way for certain functions to run. At one point, he discovered that he needed to upgrade his entire source code to a newer Python version to accomplish what he needed. He caught it early enough so he only lost a few days.
- > William built the web site on the actual distribution.

- > John did testing on the python testing engine.
- > Finishing the tutorial was a HUGE hurdle to clear.
- > Having that python engine up—knowing he didn't reuse code and it was all his own design was the biggest accomplishment. That was huge because it gave users real-world experience to get them on the keyboard using it.
- > Virtualization created a computer inside a computer. They spent hours doing tests. The virtualization is unique.
- > Being invited to present at the ICDW was a tremendous honor.

## Where are they now?

Following graduation in December 2011, John was hired by a prominent federal agency and moved to Maryland.

William is the Network Administrator for a school district that includes a district office, a high school, a middle school and three elementary schools. Some of the technologies that he uses on a daily basis include: Cisco ASA 5510 firewall, Cisco switches of various models, Extreme Networks switches, Cisco wireless LAN controllers, Cisco light weight access points, a web filter, spam filter, Windows Server 2003/2008 (Active directory, group policy, DHCP, DNS, print services, windows update services).

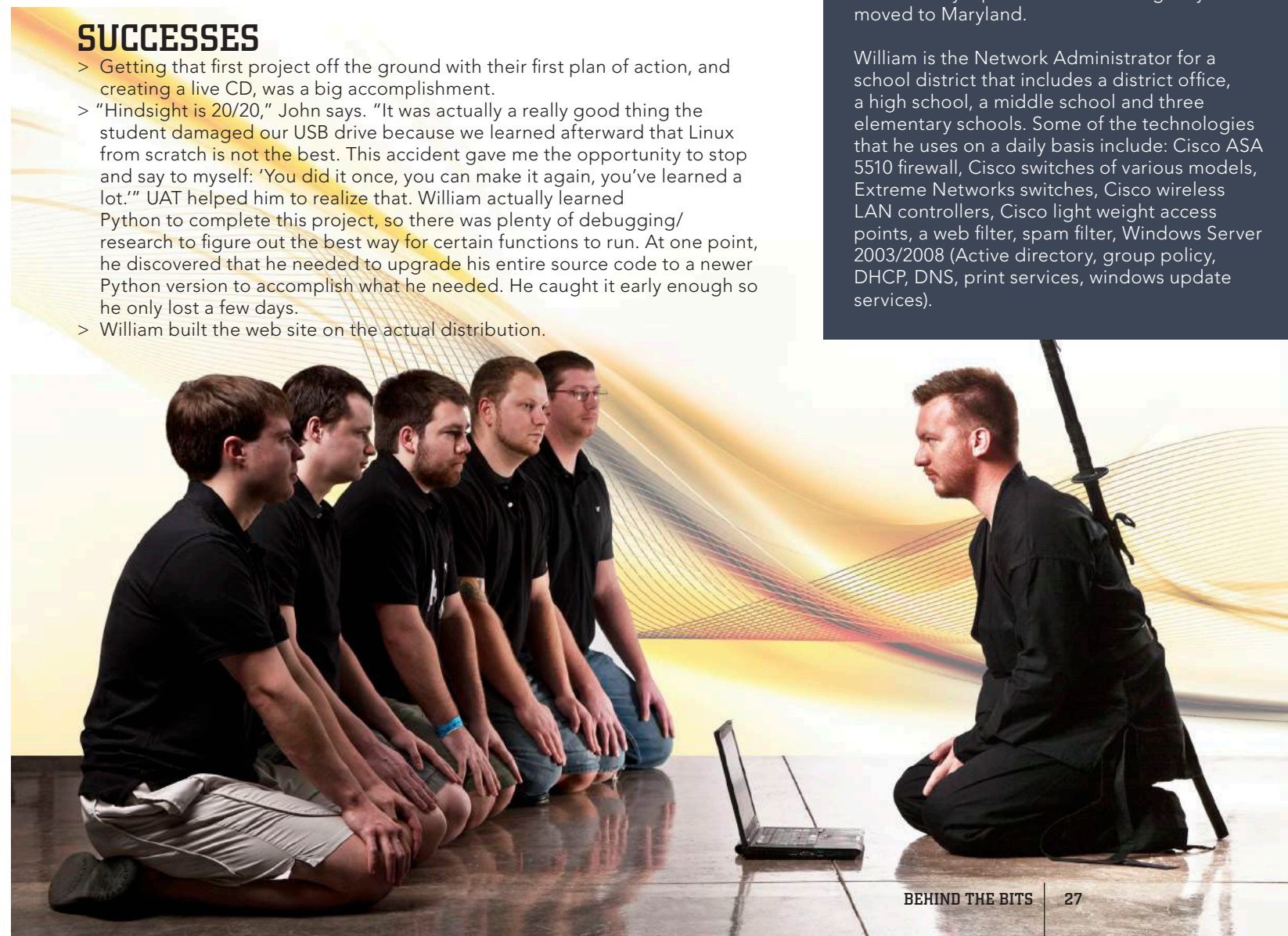



## INCUBATING TECH GROWTH

## ACCELERATING IMPACT

# Students Win City of Surprise Tech Challenge.

## RADIAL IMPACT TEAM

## RADIAL IMPACT TEAM

**Project Lead: Joe Gohn**  
Major: Game Design  
Year: Senior  
Joe is Project Lead/Engine Programmer at Radial Impact.

**Lead Programmer: Gregory ("Raj") James**  
Major: Game Programming  
Year: Senior  
Greg is Assistant Director for Campus Villages (aka Founder's Hall Dormitory at UAT) and Game Programmer at Radial Impact.

**Network Programmer: Aaron Khan**  
Major: Advancing Computer Science  
Year: Senior  
Aaron is a Network Programmer at Radial Impact.

**Physics Programmer: Cody Robinson**  
Major: Game Programming  
Year: Senior  
Cody is a Game Programmer at Radial Impact, maintaining and supporting the Blanced Almond Game Engine for War Plan Red. He also is a Resident Assistant for Campus Living Villages (aka Founder Hall Dormitory at UAT).

**Animation Programmer: Neal Valiant**  
Major: Game Programming

**Tools Programmer: Pete Ersteniuk**  
Major: Advancing Computer Science  
Year: Senior  
Peter is a Developer at Radial Impact.

**Tools Programmer: Francis Gamble**  
Major: Game Programming  
Year: Senior

**Systems Programmer: Daniel Strayer**  
Major: Game Programming  
Year: Senior  
Daniel is a Game Programmer for The Wahlin Group in Tempe, Ariz.

**Web Development: Jaylyn Dawson**  
Major: Tech Product Design, Human Computer Interaction  
Year: Senior

**Lead Artist: Patrick Gantt**  
Major: Game Art and Animation  
2012 graduate  
Patrick is a Weapon and Vehicle Artist at Radial Impact.

**Character Artist: James Scott**  
Major: Game Art and Animation  
2012 graduate  
James is a collector at Progressive Management Systems in Las Vegas, Nev.

**Senior Artist: Blake Bjerke**  
Major: Game Art and Animation  
2011 graduate  
Blake currently is exploring career opportunities.

**Concept Artist: Odom Keo**  
Major: Game Art and Animation  
2011 graduate  
Odom is a Concept Artist at Another Day Gaming.

**Environmental Artist: Dennis Porter**  
Major: Game Art and Animation  
2012 graduate  
Dennis is an environmental and prop artist for Real Dedicated Games.

**Character Artist: Joshua Morrison**  
Major: Game Art and Animation  
Senior  
Joshua currently is a Concept Artist/Modeler for The Afflicted and Collaboration Project, and exploring full time career opportunities.

**Lead Designer: Devin Sherry**  
Major: Game Design  
2012 graduate

**Writer/Designer: Zack Sparks**  
Major: Game Design, Game Programming  
2012 graduate  
Zack is a Game Designer/Writer for Team Afflicted and Radial Impact, and Creative Director for ColorMatch Team, a small, mobile game team.

**Level Designer: Estevan Lopez**  
Major: Game Design

**Lead QA: Cody Furr**  
Major: Game Design  
2012 graduate

## OVERVIEW

Thanks to UAT's innovation and community partnerships, a team of UAT students have started their own game design and production company called Radial Impact. The AZ TechCelerator's incubator program in Surprise, Ariz., awarded space to Radial Impact, and now the sky's the limit in how big their game design business can grow.

The team of 25 includes 18 UAT students and seven from the Art Institute of Phoenix helping them out.

"We're not just making games. We're making a unique gaming engine that enables the creation of cinema-quality graphics in real time," says senior Joe Cohn, a Game Design major from Elkhart, Ind. "We're pushing technology on the engine side of things. We want to take what's out there, make it better and be on the forefront of pushing our technology to the next level."

There are other commercial engines out there. Epic Games uses the Unreal Engine, the most widely used game engine on the market. But rather than paying to use another company's game engine, Radial Impact built Blanced Almond, a very powerful engine they can use to make their own games.

Joe and his team wanted the security of knowing if something happens to the engine or one of the games developed with the engine, their local crew can troubleshoot because they know how it works.

With this new space, now Radial Impact will be able to concentrate more fully on using their engine to create *War Plan Red*, a game where *Call of Duty* meets *Ace Combat* scheduled for release in late 2013 on Steam. Now that they have the resources to develop games, other ideas are being thrown around.

## HISTORY

The game engine project started out with Joe and Patrick Gantt (graduated 2012 in Game Art Animation) working together on their Student Innovation Project. Joe built the first version of the engine in C# with XNA by himself in about two months. They finished that version of the engine and brought on the rest of the programming team. Together, they prototyped the game *War Plan Red* in about two weeks and decided they needed to prepare themselves for the AAA game industry by tackling this project in the industry standard language (C++). They have been working since March 2012, and seized the opportunity to apply for free office space at the AZ TechCelerator for a year. They pitched their idea for the game engine and won the competition. Their project turned into the start of Radial Impact.

Once the engine was done, the team brought on six other UAT programming students. When they realized how fast and skilled we are together, they transitioned to a different, more powerful language. They wanted to write all of the code themselves, not use what's out there.

Radial Impact moved into the office space last April. Joe will be pitching in front of investors to help keep the team together for long enough to ship the full engine and get their feet on the ground. For now, the team works on good faith that this project can be greatly successful in the gaming industry.

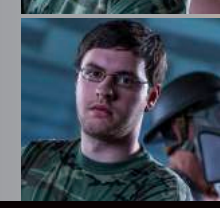
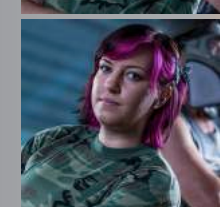
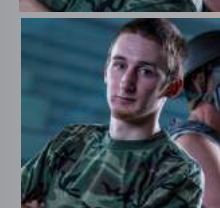
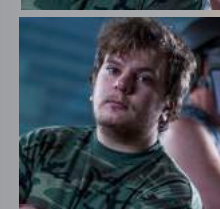
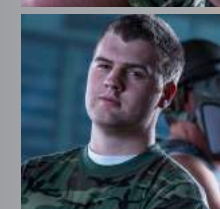
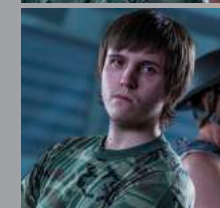
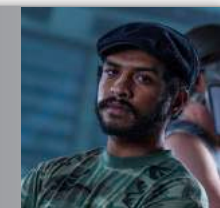



ACCELERATING INNOVATION FOR

# MAXIMUM IMPACT

## AZ TechCelerator radial impact

Winning a competition and receiving an award is an impressive accomplishment. Winning a competition that secures you free incubator space for one year is the opportunity of a lifetime.



### DETAILS

The Radial Impact team is not just making a game. They're making a unique gaming engine that enables the creation of cinema-quality graphics in real time. They're pushing technology on the engine side of things, taking what's out there, making it better and being at the forefront of pushing technology to the next level.

Radial Impact is creating a multi-platform game engine known as Blanched Almond. The name for Blanched Almond came about when Joe and Patrick, the team's lead artist, were making the first build of the engine.

"I asked Patrick what color I should make our background," explains Joe. "After looking through the list of colors, he said 'What about Blanched Almond?' Then he quickly said, 'You should totally call the engine Blanched Almond!' We laughed; it stuck."

The engine is built in C++ with DirectX11 and OpenGL. The editor for the engine (the software the developers use to build games, known as the Nutcracker Editor) is built with WPF (Windows Presentation Foundation).

When you open the editor, level designers start with a blank screen. They work their way through designing levels by importing 3D models into place to construct massive 3D game worlds. One thing that makes the Nutcracker Editor unique is the ability to collaborate on a single level over the internet. Joe explains it this way: "Our Lead Designer, Devin Sherry, might want the help of our other level designer, Estevan Lopez, on one of his levels. The problem with any other editor is that Devin lives in New York, while Estevan lives in Arizona. With the Nutcracker Editor, Devin and Estevan can log into the editor and see the same level at the same time similar to the way that Google Docs works."

### SUCCESSES

> Had it not been for the opportunity at the AZ TechCelerator, Radial Impact would never have even considered turning this project into a company. The City of Surprise's generosity is what helped motivate them to make this their full time job.

> When the Radial Impact team first set out our goal of making the prototype for the game in the C#/XNA version of the engine, they planned on taking a month to complete it. It only took two weeks to finish every task. They learned how well they work together and can do amazing things when they combine their skills together.

> "Making a game engine from scratch alone is a really big project, but combine that with making a game as well and it becomes a great venture and I'm excited to be a part of it," says senior Raj James. "Ever since we got the space we've been

snowballing towards becoming bigger and better. We've always been super dedicated but now we've turned up the volume even more."

### CHALLENGES

>When Joe got to the multi-player support for the engine, he realized he needed help and recruited his roommate Aaron Khan, a May 2013 Advancing Computer Science graduate.

> It's a challenge to make large video games in a timely fashion and at a high caliber. By rebuilding an engine from scratch, Radial Impact is able to customize their Blanched Almond engine to the needs of any developer. The engine is designed to be modular so that any developer can use their own software with the engine seamlessly.

### FUTURE

Production of the game *War Plan Red* has been pushed back a bit so that the team can focus on perfecting the engine. They want to be able to license this software to other developers so that other games can be made using their technology. They are looking at the first "Release Candidate" build of the engine sometime in 2013.

Once their lease is up, if they are doing well and *War Plan* is doing well, Radial Impact will probably stay there and keep working on something new. "We want to be self sufficient so that every game we release will fund the next game we release," says Joe. They are hoping to find an investor to help them demonstrate Radial Impact's full capabilities to the gaming industry. For updates, visit [www.facebook.com/radialimpact](http://www.facebook.com/radialimpact).

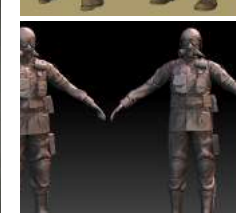
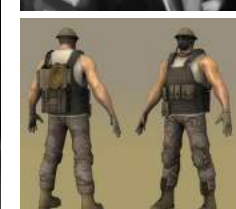
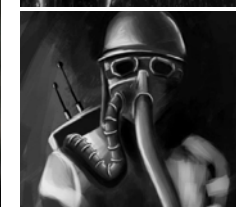
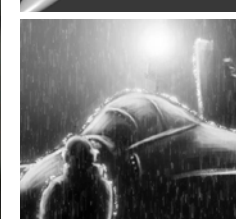



ROBOT BOLDLY GOES WHERE HUMANS

# FEAR TO TREAD

## OVERVIEW

If you can imagine an extreme RC car on steroids, then you begin to get an idea what innovation can do at UAT when you have the right resources and current robotic technology as fuel for development. UAT Robotics and Embedded Systems 2012 graduate Stephen Harper developed the Small Scale Vehicle Semi-autonomy and Obstacle Avoidance, which can go as fast as 55 miles per hour and weighs only 25 pounds.

The terrestrial vehicle may be used to assist or replace humans in dangerous scenarios or difficult to navigate terrain environments.

Potential application of the vehicle's use includes scenarios for military use, or for disaster recovery such as in an earthquake or other difficult to navigate terrain environments where roads are inaccessible to full-size vehicles.



## DETAILS

Equipped with a 2.5 hp 2-stroke engine, the vehicle is designed in size and varying speed capacity to more easily sense and navigate unpredictable terrain environments and send data, including live video, back to the base station.

Stephen used a lot of proprietary systems for terrain evaluation and object detection. He also custom built sensor rays that processes data, evaluates its relevancy and determines how to proceed.

"A camera system for object detection can be expensive and complicated," says Stephen. "My project is unique because I wrote all the code for the system, which reduces the need to purchase a system and minimizes overall operational costs." His project also requires little computer power.

Stephen also wrote client software using the Google Maps APO application program interface, which allows the setting of waypoints to find its own way there while avoiding obstacles. When you give it a destination it will find its way there on a path of least resistance.

The vehicle communicates wirelessly with base station X-Bee radios 2.4 ghz spectrum that sends the data to a laptop with client software. The system is designed to have someone overseeing the vehicle's journey on a laptop.

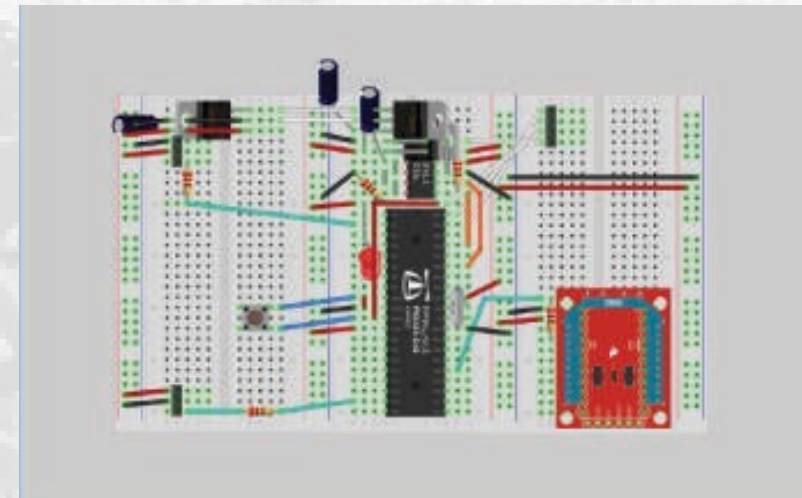

## SUCCESSES

Mission accomplished! The final prototyped version of the platform is a success. This includes the platform itself in addition to sensor arrays, electronics packages and support hardware.

Stephen successfully developed software that included code to support basic obstacle avoidance and necessary library implementations to communicate with support hardware.

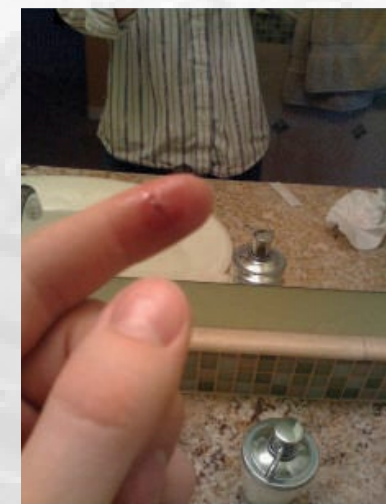



STEPHEN HARPER

# SML SCALE VEHICLE

Multiple implementation issues occurred with regard to the choice of a specific microcontroller for the project.

Discovering the intricacies of a highly proprietary programming language adds to the overall complexity of the project and several desired (although not requisite) modules and functions have been foregone in the final prototyped platform.

## Challenges

With proper funding and community development, the main objectives of the platform can realistically be realized and implemented in real-world scenarios.

Future project development will likely replace the Parallax Propeller core with a more powerful and well established microprocessor such as a robust PIC or ARM architecture. Further analysis of the efficacy of various sensor array combinations will likely also be explored. Significant development of autonomous functionality remains to be realized in addition to enhanced obstacle avoidance procedures, including more robust data filtering algorithms.

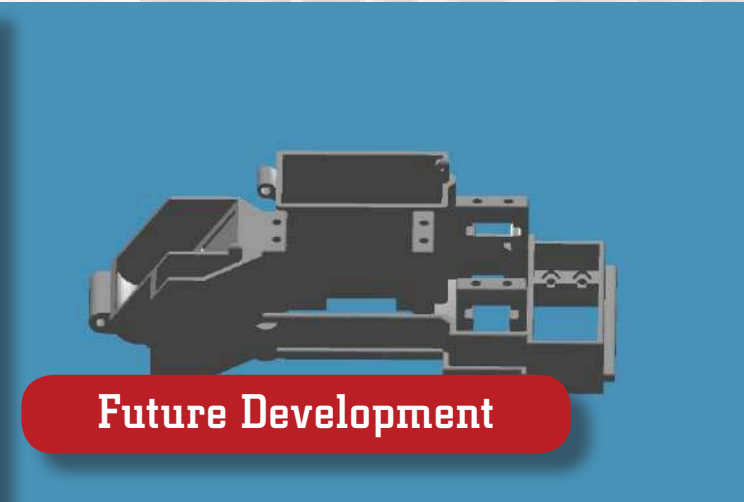

Future Development



## Where is he now?

Stephen's independent project, along with a multi-faceted education background, helped prepare him for his new career as an Embedded Systems Engineer at Cummings Engineering.

## More Details

### Platform Construction

The base platform consists of a 1/8th-scale Nitromethane powered terrestrial vehicle including basic obstacle avoidance and path-finding in addition to two-way data communications and mesh networking. The platform is all wheel drive and includes fully functional differentials, a two speed automatic transmission with reverse functionality. A full rebuild of the base platform was required prior to the addition of any of the electronics packages, sensor arrays or support hardware. The completed platform with these modules attached is the main deliverable objective for the project in addition to all requisite code and documentation.

### Design

Parts are designed using appropriate techniques as needed to produce the desired components. Physical components such as the radio tray and roll cage are sketched out using measurements obtained from the base platform, then created in three dimensions using CAD software. Numerous additional components and modules are required to maintain safe functionality of the vehicle and to support the accommodation of various electronics packages. In many cases, off-the-shelf components are not available to meet these requirements.

### Implementation

A 3D printer is used to make parts which will not encounter a high degree of physical stress (such as the radio tray). Components which will encounter high torque or require impact resistance can be machined or cut on a water jet table (such as the roll cage). Small parts or components requiring relatively little modification are simply milled or machined as needed.

### Electronics/Code

The primary microcontroller and control interface for the platform is a Parallax Propeller core, an 8 core micro with built-in support or available libraries for much of the platform's required functions. Code for the Propeller micro is written in a proprietary language called SPIN. Electronics in use on the platform are a GPS unit, X-Bee transceiver module, PING))) ultrasonic sensors, forward facing camera module and a variety of servos to control the various physical interfaces of the platform.



KILLING FLOOR CAN YOU SURVIVE THE

# ZOMBIES AT UAT

## Killing Floor



### OVERVIEW

Zombies are invading UAT in the new game level Jon Hahn created with the editor version of Killing Floor.

"The story for the game Killing Floor is basically there are mutated zombie creatures, and the players must fight/destroy/kill these creatures to survive," says Jon, a junior majoring in Game Design who hails from Roselle Park, NJ. "As for my level, I knew that there are a lot of 'zombie-fans' at UAT, so I figured that creating UAT in this game level would be really cool. Players are trapped inside the UAT building and must survive the zombie horde."

Jon wanted to make a fun level that people at UAT, or anyone new to UAT, could play it and appreciate. He also wanted to develop his level design skills and add a solid portfolio piece.

The project is now complete, a fully playable level anyone can download from Steam. Jon is in the process of contacting other websites who would be willing to host his download. The game can be downloaded at <http://store.steampowered.com/>.

**IMPORTANT TO NOTE:** All the art assets that Jon put into his level were already made by the game manufacturer of Killing Floor: Tripwire Interactive, they were changed to fit his UAT level.



KILLING FLOOR CAN YOU SURVIVE THE

## ZOMBIES AT UAT

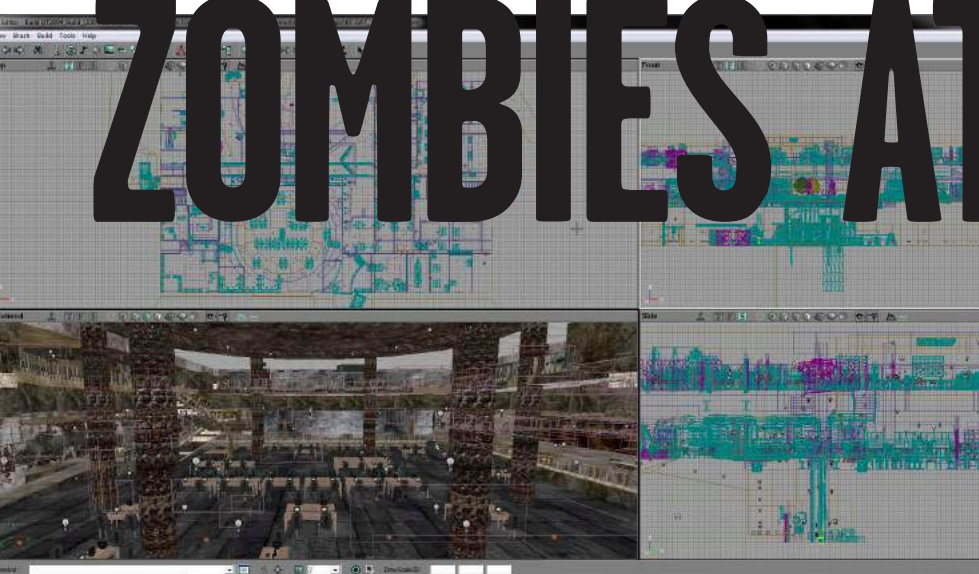

## HISTORY

Jon has always loved everything action adventure.

"Since I was very little, I just really wanted to find the best school," says Jon. "UAT stood out during a career fair I attended. I was so impressed that UAT traveled across the country and displayed such enthusiasm, that it made me really want to attend the Fly-In Geek program."

Jon's evolution of learning at UAT—with the support he received from Professor David Wessman (who he refers to as his mentor) and the University's Synchronic Learning methodology emphasizing real-world, hands-on learning—gave him the experience he needed that resulted in the creation of a successful game level.

## DETAILS

In Jon's UAT level, players are trapped inside the UAT Commons and must survive the zombie horde.

Jon's adaptation is completely separate from the Killing Floor game, although includes many similarities. He created his level using the editor version and assets from the real game.

The project is now complete, a fully playable level anyone can download from Steam, which hosts the map. Jon is in the process of contacting other websites who would be willing to host his download. Visit <http://store.steampowered.com>.

It was important to Jon that he be as authentic as possible when recreating the UAT environment. He spent a lot of time walking around campus, in every nook and cranny, and taking about 200 photos so he could create a detailed campus map and build the design. He also included a store in the game level's Bindery where you can purchase gear upgrades.



Jon's right hand man was Dylan White, a sophomore majoring in Digital Video who offered him help with play testing and gave advice on how to improve lighting issues.

## How you play the game:

Two players start the game. Thirty zombies will spawn randomly in the map (in his UAT level, the zombies can spawn in any room), and players must defeat/kill the zombies to survive wave one. Once all the zombies are defeated, players are given 60 seconds to find where the store "trader" is located (in the UAT level, the store is located in the Bindery). After the 60 seconds are up, the next wave starts. Wave two has 40 zombies, and players must survive. This continues for 10 waves (fight zombies, visit store in between waves). Each wave adds more zombies, and increases difficulty. Once the players reach wave 11, the Boss spawns. In order to complete the level, the player(s) must defeat the Boss, along with the wave of zombies. This is basically a typical Killing Floor type of game.

After the players defeat a wave, the "trader" opens up a shop located somewhere in the map you are playing on. Jon's trader is located at the Bindery. Players have a specific time limit to find where the trader is located and then purchase either weapons, ammo, or armor. Players get money from killing zombies in the previous wave that they can use at the store. Within a specified time limit, the players purchase weapons (or can sell weapons back) and other equipment to prepare for the next wave. After the time limit is up, the trader store "closes" (usually physically closing a door, or shutting a window the players look through). When the store closes, players are teleported to right outside the store. The end of the time limit (and as soon as the players teleport) also begins the next wave.

## CHALLENGES

Shortly after he first arrived at UAT, Jon decided to try creating an early type of level design from the Left 4 Dead video game for a class assignment in Professor David Wessman's class. "The level was wonky, so I scrapped the project," explains Jon.

This challenge turned into a tremendous learning opportunity. After he gained more hands-on experience at UAT, he decided to try again on his own to create his UAT zombie Killing Floor game level.

## SUCCESSES

Although Jon hadn't told anyone yet, it didn't take long for news to travel throughout much of UAT about his zombie game level once it was completed and available. One day in the Commons building, six UAT students just happened to be playing it when Provost Dave Bolman stopped by and witnessed the game in action.

He was very impressed with how well Jon represented UAT and the zombie theme that runs throughout many aspects of UAT life. Jon admitted that recognition felt really good.

## WHERE IS HE NOW?

Jon is a junior who aspires to be a level designer and is working to get his name out into the game industry. He realizes experience is the key to helping him build his portfolio.

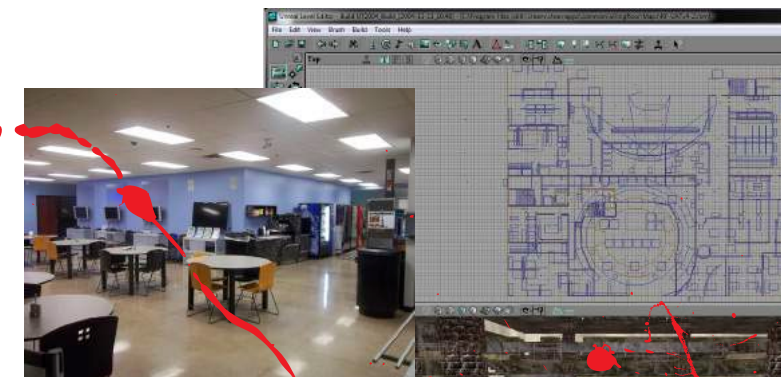



IT TAKES STEALTH AND RECON TO

# SECURE THE WEB

## OVERVIEW

Ensuring a safe and secure web environment requires both stealth and reconnaissance. Charles Neitzel's SIP, Stealth Recon, can attest to this.

In the world of net security, there are many programs out there that conduct security checks, such as port and vulnerability scanning, to ensure a safe and secure web environment. But remembering all of these programs and when to use them can be a challenge whether you're using your home computer or work in an office.

That's why Charles, a Network Security and Technology Forensics major who graduated in December 2011, developed the Stealth Recon web interface to group programs for niches like port and vulnerability scanning with an easy-to-use online format that does the work for you and gives you the results.

"You don't have to remember all of the command line stuff, and you don't have to use multiple programs, because that's what the backend of the web interface will do for you," says Charles, who hails from Salt Lake City, Utah.

## DETAILS

Stealth Recon is a name was derived from the early stages of the penetration testing process. The initial phase of the process is reconnaissance. The reconnaissance phase is broken down into two components—passive recon and active recon. Active recon actually involves going out and probing the target system; this is an action that would be detectable (in most cases) by the owner of the target system. Passive recon involves gathering information that is publicly available—WHOIS (registration information), DIG (domain information groper), Google searching, etc. The actions performed in passive recon are undetectable by the owner of the target system, hence the word "stealth." The project was originally designed to do nothing more than automate reconnaissance tasks, so that's where the "recon" portion comes from.

Unlike the security suites with tools you select one by one, Charles designed Stealth Recon to be fully automated, group multiple programs together and conduct the scanning for you. He holds the copyright for the idea and was the project manager throughout the development. The project currently is in the Phase 1 Alpha Stage, with functionality limited only to a rudimentary WHOIS and DIG query on an entered URL.

The program also serves as a network enumeration tool, inventorying all computers and allowing you to see how networks and servers are connected.

The end goal for the project was originally to have an all in one penetration testing suite. This would include the existing versions (more refined) of WHOIS and DIG, as well as Google Hacking, nmap, Nessus and Metasploit functionality. The project is targeted primarily at information assurance professionals, but is designed to be simple enough to use for say, a general IT manager who has little to no technical knowledge of information security audits/vulnerability assessments/penetration testing.

## CHALLENGES

- > Former UAT student Ronald A. Richardson served as the project's main programmer/designer, although he left UAT prior to the project's completion.
- > As a result, Charles has no source code/web server access for the project.
- > Project management is hard—ultimately—although it's useful to learn because it applies to the real world.
- > There were plans for an Android/Apple iOS version of this web application, although it would not have had the full functionality of the web version.
- > Scheduling conflict prevented him from presenting at the ICDW.

## SUCCESSSES

Charles' project had so much potential that he was invited to present it at the International Cyber Defense Workshop (ICDW). Although he had a scheduling conflict that prevented him from participating, he feels "the invitation has since become a topic of great pride in myself and an indication that people are noticing my work; it's a great feeling. Although I didn't actually present at the conference, I still feel like it has been very beneficial to me. I am very honored to have gained such recognition and exposure to the international information security community. It's really given me a lot of motivation to pursue my personal goals knowing that I can achieve some really great things that I never thought possible."

## WHERE IS HE NOW?

Charles graduated in December 2011 with a double major in Network Security and Technology Forensics. He has accepted a position as Control Systems Vulnerability Analyst with a government agency in the Washington D.C. area.



# VISUAL NETWORK ANALYZER; STUDENT SHEDS NEW LIGHTS ON SECURITY ALERT



## OVERVIEW

UAT students don't just solve problems—they often innovate with colorful, creative solutions. That's just what 2011 graduate John Faulkner, a Network Security and Network Engineering dual major, has accomplished with his Visual Network Analyzer (VNA), an intrusion detection system. The 8"x8" matrix cube prototype is designed to accentuate the overall functionality and incident response process for security and network operations centers.

The Phoenix, Ariz., native envisions a future where network traffic, intrusions and exploitations are indicated with different "graphic moods" to represent unique circumstances and provide real-time alerts that are visible not just to one person sitting at a computer, but to many people throughout the room.

He wanted to create a device that will help people notice incident activity faster, as it happens, without the device being "intrusive or annoying" with noise. What's a problem solving alternative? Aesthetic design—John actually envisions the project accentuating a room's environment and changing a room's entire color.

The goal is for John's VNA to serve as a focal point to the physical design of any Security or Network Operations Center. He hopes his VNA will fill a void for small businesses that are trying to expand their security areas but haven't done so yet because of cost or priority.

## HISTORY

Like so many projects, ideas are morphed from discussion and exploration of ideas. The UAT double major in Network Security and Network Engineering was brainstorming one day with Professor Al Kelly, bouncing ideas around as students and professors often do. Professor Kelly jokingly mentioned a disco ball and how it shines lights in patterns and colors in a room.

That discussion sparked John's interest and he decided to take that idea one step further to create his VNA concept. John also has been inspired by national network security expert and entrepreneur Steve Ocepek, who pioneered the "Cereal box" and "meter" to create visual representations of network traffic. Steve demonstrated these programs during the Defcon 19 Cyber Security Conference, which John attended. This helped him further develop his VNA concept.

And it was Professor Vesna Dragojlov who encouraged John to think out of the box from an algorithmic art perspective and innovate something that could light up a room, literally. She showed him different ideas from a waterfall of lights to sensors that change a room's entire color to green or red.

A disco ball was one model John explored; a security camera mounted on a dome yet another.

## DETAILS

John's LED matrix prototype, with eight rows of lights across and eight rows up and down, includes Arduino Uno, Ethernet Shield and Color Shield—an initial design that will serve as a springboard for other designs being considered.

John's VNA is designed to alert IT personnel, sending a message that says, in essence: "I can't do anything about it but I'm alerting you that something out of the ordinary just happened so you need to take the proper precautions."

The project is network and host based, designed to audit security threats and policy violations, and monitor traffic for suspicious activity. It will sniff the network for information that is out of the ordinary, malicious, and scout network activity patterns. It will look not just within the network but also outside the network.

Advantages to implementation include:

- > System activity monitoring
- > Auditing
- > Analysis
- > Policy enforcement

Through Arduino Language that is based on a set of C/C++ functions and open source libraries from Arduino.cc, the VNA is designed to detect unique network packets and

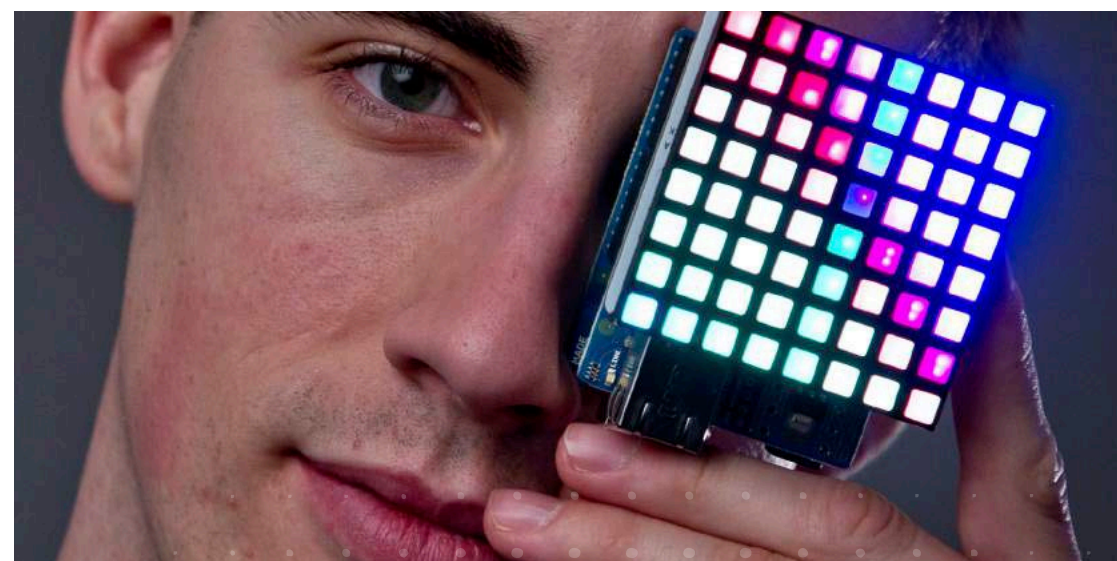

protocols, with exclusive colors assigned to the latter to give a dynamic face to and break the monotony of lists of text.

The protocol color spectrum includes: 1) TCP—Green, 2) UDP—Blue, 3) SYN/ACK—Yellow

## CHALLENGES

John sought out to identify the problems that exist in current intrusion detection systems:

- > How long will it take to identify suspicious activity? Incident response time is an issue.
- > Log management: How will incidents be reported?
- > Log information interpretation
- > Reactive technology
- > What procedures are in place to identify and report activity?
- > Who will be contacted?

His project addresses these weaknesses in current systems. The personal challenges John faced helped him learn a lot about programming, including how circuit boards work and how programs interact with hardware. Learning how to make certain things turn on and off, and making the hardware understand where it's pulling its information from and where to send it to, were his biggest challenges that turned into his biggest growth opportunities.

## SUCCESSSES

- > Ability to identify traffic patterns and represent those with certain colors
- > Provides the framework for an innovative business solution

## FUTURE

John envisions his prototype will have multiple development phases. Visuals and physical designs, and creation of more network protocols represented by various colors are planned, along with a vulnerability analysis for signature detection, anomaly detection and detection of malicious behavior.

His vision is to create different versions, one that's cost effective version for the classroom environment and another customized for the business environment. Features include:

- > Organized patterns and colors emitted through a dome to help organizations and individuals monitor network traffic, detect security issues in real time and improve incident response time
- > Ability to determine "good" network activity from "bad"

- > Randomly generated, more chaotic, a visual experience that will be different each time it is initiated
- > Mountable anywhere
- > Ethernet Shield connectivity

Beginning phases will possibly be implemented within UAT in the Cyber Security Cave and Commons area.

Surrounded by inspiration at UAT and beyond, John has learned by what others have done and is fueled to take things to the next level. Take IBM's super computer, Watson, for example. He says innovations like these drive the future of business.

"Watson might have been a little bit of inspiration to me," says John. "The VNA is my Watson, a super computer dedicated to analyzing anomalies and letting them know when it is happening."

## WHERE IS HE NOW?

John's project currently is on hold as he begins a new job as a security analyst at Apollo Group, Inc. in Phoenix, Ariz. He plans to complete it one day.



KASEY NORMAN'S

## TRACK BOT

## AUTONOMY

Into the Danger Zone:  
**Kasey Norman's  
Affordable  
Recon Bot**

## vehicle

Kasey wants to apply his project to make a difference in multiple ways:

**1** Solve a real world problem to create terrestrial unmanned vehicles that perform reconnaissance—at a reasonable cost. Kasey wants to prove that police, firemen and the DoD can produce and use something value-priced yet effective at entering risky environments and performing potentially life threatening tasks. The more cost effective production is, the more these bots can be made available. With his design, Kasey's figuring his project can be produced at a cost of a few thousand dollars vs. what currently is on the market at costs upwards of hundreds of thousands of dollars.

**2** Provide a learning platform to schools to help teach programming to elementary and middle school students.

**HISTORY**

This bot started out as a kit Kasey bought but never did anything with until UAT helped him realize the innovation that building it would bring.

**DETAILS**

Kasey's robot includes a motherboard, battery, touch screen database to scan the area, basic navigation and the ability to map terrain and the environment. Xbee is built inside of it for communication with the base station and with other robots. The robot has built-in sustainability to keep from self destructing if disconnected from the base station computer.

Although the base station is able to handle multiple robots, Kasey is designing his project so when you have just one bot it can be programmed from any computer. Going this route, you need a separate Xbee radio for about \$30 or \$40. He's figuring the bots themselves will cost in the \$500 range with the battery pack. Laptop software for programming the robots is free.

**OVERVIEW**

This SIP is gaining traction—robotically speaking! Junior Kasey Norman's semi-autonomous vehicle with intelligence in a base control unit is a semi intelligent "track bot" that has a rover design, with tracks for wheels. Kasey is a Robotics and Embedded Systems major originally from Wichita, Kan.

The bot is linked to a computer base control unit that receives data from the bot and processes it to determine and navigate location.

The intelligence is shared with the base control unit. Instead of having all of the intelligence on the robot which makes it much more expensive, the base control unit monitors, navigates and maneuvers one or more bots. Outside, the range between the base station transmitter and the robot is two miles. Indoors, the range fluctuates depending on interference, up to a mile.



KASEY NORMAN

# Kasey NORMAN

## Junior Kasey Norman's Semi-Autonomous Vehicle with Intelligence

### Robot's creation

The upper body of the bot and all sensor mounts were designed by and built using UAT's 3D printer and laser cutter on campus.

Arduino software was used to program the bot, which is available for free from <http://www.arduino.cc/>. Kasey also is planning to use a graphical programmer.

The only true kit piece was the Rover 5 platform. All the other boards are in the process of being made into one. Components include:

- > The rover base: The Rover 5 Robot platform
- > A pair of Xbees
- > An Arduino Mega
- > A Pololu Dual VNH5019 motor controller
- > Infrared range finders (have become obsolete—looking to replace)
- > Xbee Explorer board for easier connection to the Arduino
- > Battery: LiFePO4 9.6v 3A pack  
"[The Rover 5 Platform] made for a good base as they are cheap and easy to get a hold of and packed with all kinds of goodies such as motors and a track system making them a little more terrain versatile," says Kasey. "[It] also had built in quadrature encoders which allow me to poll data to help me determine the distance moved how fast and in what direction with the help of a proportional-integral-derivative controller (PID controller).

### Base station creation

As for the base station, it runs Ubuntu Linux (<http://www.ubuntu.com/>) and ROS (Robot

Operating System. <http://www.ros.org/>). These are both free, open source software on the base station.

Components include:

- > Mother board: Asus AT3IONT-I Deluxe
- > Harddrive: 32 Gb Patriot SSD
- > Ram: 4Gigabytes of GSKills DDR3 Ram
- > CPU: Intel Atom 330
- > Networking: Bluetooth and WIFI built on board
- > Touch screen: Lilliput 7" SKD open Frame Touch screen (VGA)
- > Battery: Custom Designed 12.8 LiFePO4 9.9 AH pack
- > Case: Custom designed by Kasey and laser cut at UAT using acrylic

### CHALLENGES

- > How to model this bot was a challenge. Kasey had the idea but needed a body to make it a reality.
- > He had the tools but needed to learn more about them. He then started looking at every resource he could find and devoted one of his desktop monitors to "how to" videos while the other monitor displayed Parts Data Sheets.
- > Building the assembly out of thin air inside the software also was challenging, but it was invigorating for Kasey and became almost addictive to see something he was making taking shape.

### SUCCESSSES

- > Modeling, engineering, and designing the entire track bot body was

completed in 48 hours. This was quite the task as Kasey had limited knowledge of Inventor and the only way to learn was to dive in and get better.

- > Kasey got the bot moving with remote control using a keyboard to control it. "It is quite a successful moment to see your bot alive and moving even if it just a motor test but even better when you can control it directly," says Kasey.

- > One day in UAT's Robotics Lab, Professor Ryan Meuth helped Kasey realize that instead of processing so much high level data on the bot itself (making the bot become pricy when components get really small), he could send data off and have the ROS (Robot Operating System) process all this data on a cheaper, remote system.

### FUTURE

Kasey currently is finalizing a redesign, taking all the little bits and pieces inside

the bot and integrating them to become a single board. This redesign cuts down the wire mess, makes it neater and cleaner inside and makes it easier to pull out a part to fix or replace.

"My hope is to get this bot to where it needs to be, able to self navigate obstacles with its current sensor package and do even more once I have it finished," says Kasey.

### WHERE IS HE NOW?

Once Kasey completes his undergraduate degree, he wants to continue on to complete his master's degree and hopes to enter the medical robotics field—robotics that can assist the elderly maintain independence.

Kasey is a full-time student and a full-time employee in Phoenix as a Surface Mount Technology Technician. (His portfolio that included his SIP helped him get the job!) He's volunteered in the past to help students at Coronado High School with their after-school robotics program and is hoping he'll find time again to help with the FIRST® Robotics Competition Arizona Regional. He loves doing these events.

Once he completes his degree, Kasey wants to continue on to complete his master's and hopes to enter the medical robotics field—robotics that can assist the elderly maintain independence. He also wants to work on the da Vinci robotic surgical system.

He has personal reasons for wanting to apply his passion to the medical field: His mother is a cardiac surgery nurse and he has Multiple Sclerosis.

"My body is attacking my own nerves, which will eventually impact mobility," he says. "My degrees will give me the ability to design devices that help me continue to walk."

### HOW THE SOFTWARE WORKS

The bot's parts connect back to the Arduino, the brain. It processes data from the Xbee (radio/mouth/ears of the bot) which is sent from the base station and gives instructions on what the bot needs to do. The Arduino then polls data from its sensors to "see" what is around the bot, then determines if it needs to navigate around it or if it needs to send data back to the base station for more information. From there, it determines how it needs to move and then sends that data to the motor controller. While this happens, the PID controller polls data from the encoders in the base to determine how the bot is moving in the world and correct issues by adjusting the speed of motors automatically. Although the bot is moving, it is constantly checking to see if it's going to hurt itself. This is achieved by sensors attached to interrupts on the Arduino. If the bot is moving forward and one of the sensors determines there is a sharp drop ahead, it will stop in place and send data back to the base station for instructions on what it should do. After it determines the best course to avoid the obstacle, it continues its given task until complete.

### HOW THE HARDWARE WORKS

#### Power Management:

The battery is fed to a power distribution bus, which powers all the hardware including sensors, Arduino, Xbee, motor controllers, and any other peripherals he decides to add such as LEDs, cameras, etc. A battery charge circuit has been designed to automatically switch power and put the Arduino in a waiting mode until it is disconnected. Kasey currently is waiting on the new revision of the board to tweak and fine tune this feature.

#### The Core:

Arduino is connected to the infrared sensors, which read via analog. Two sensors, one in front and one in back, are set to interrupt so it can stop the bot from falling over an edge. These sensors were placed at a 30 percent angle to help detect sharp drops such as stairs. The encoders in the base are connected to interrupts on the Arduino and digital logic pins to watch data coming back from these bots. The Xbee is connected to the TX and RX lines of the Arduino and is then read via serial data being sent back and forth. The locomotion of the bot is achieved with the Pololu Motor controller connecting to Arduino to receive data from Arduino on how to move via the PID function—adjusting to the correct, consistent speed.



# TOMORROW'S TECH TODAY

At UAT, students get **intense** hands-on **experience** crafting next-generation technology that will **revolutionize** business, communications, entertainment, forensics, **gaming**, the Internet, robotics, social media and **national security** for generations to come.

Get a glimpse of that **future** with these **Student Innovation Projects** in development at UAT right now.



# INNOVATING THE FUTURE

BREAKING NEWS ON UAT STUDENT PROJECTS IN GAME ART & ANIMATION THAT ARE INNOVATING TECHNOLOGY.

Game Art & Animation

# INNOVATING THE FUTURE

BREAKING NEWS ON UAT STUDENT PROJECTS IN NETWORK ENGINEERING THAT ARE INNOVATING TECHNOLOGY.

Network Engineering



## LAGOMORPH 2D Platform Game

When you combine aliens, a rabbit and other creatures in the same game, it's sure to be entertaining. But when your SIP combines the talents of a team representing UAT's Game Art & Animation, Game Programming and Game Design degree programs all in one project, it does more than entertain; it takes innovation to the next level.

Game Art & Animation major Marc Rios led a team in the creation of *Lagomorph*, a 2D platform game demo for the PC that adds a new dimension to interactive game art and design. Players control an alien abducted rabbit that must use the abilities of other abducted creatures to battle and escape his captors. It all began with Marc's concept drawing design.

Students with UAT's Game Art & Animation degree master all levels of game development and incorporate the artistic principles used in 3D video games to create a wide range of art assets and video game platforms.

### The Project

During the game, players encounter two types of hostile enemies, a guide character and two types of mobs to mimic. The abilities gained from these mobs enable players to advance through various obstacles. Players must determine which abilities work best in certain situations while trying to maintain the highest level possible without taking damage. Consisting of a single level containing six rooms, the game prototype can be accessed through an executable Unity file and controlled via an Xbox 360 controller for Windows.

### The Next Phase of Student Innovation

Marc and his team look forward to the next phase of the project. Future builds will be play tested to reduce bugs, and all finalized art assets will be evaluated for quality before implementation at a future date.



## MOTION Plus

Abracadabra! It's not magic; it's technology advancing with the wave of a hand thanks to Motion Plus, a SIP created by Network Engineering major Kory Casey.

Kory is creating the prototype for a motion detector that allows you to turn your computer on and off wirelessly, without using the power button, regardless of where the computer is located in a room. It could even be in the closet. Simply wave your hand.

It happens more often than you might think. You're on the other side of the room from where your computer is located and you want to power down or power up before you reach your computer desk or as you're moving away. Rather than take the extra time to sit at your computer while it goes through the motions, just wave your hand from where you are and voila!

Network Engineering prepares students to become highly skilled network engineers who design, implement and maintain our networked systems.

### The Project

The motion sensor is designed to be entirely plug and play. The device has a wiring harness that plugs into the power supply and also into the motherboard. For greater convenience, the motion sensor can be placed in any location within a six-foot radius in the same room, mounted on the wall or on the desk. The sensor will send a signal to a relay, which shuts down or fires up the computer.

### The Next Phase of Student Innovation

Motion Plus currently is in the development stages with hopes for completion at a future date.



# INNOVATING THE FUTURE

BREAKING NEWS ON UAT STUDENT PROJECTS IN GAME DESIGN THAT ARE INNOVATING TECHNOLOGY.



Game Design

# INNOVATING THE FUTURE

BREAKING NEWS ON UAT STUDENT PROJECTS IN NETWORK SECURITY THAT ARE INNOVATING TECHNOLOGY.



Network Security



## DOORS Adventure Game

Opening a new door in game design innovation, Game Design major Jonathan Jansma has created a prototype that fills “an unexplored niche in the mobile game market.”

Game enthusiasts, especially those who love puzzles, will be intrigued by *Doors*, a puzzle-based adventure game created with high-end graphics and intuitive controls. The game captures the realism brought out by high end art models and the Unreal Engine. Playing this game not only will entertain players but also will exercise the mind.

Game Design students focus on the design principles, skills and techniques required to create mechanics, and design documents and functioning prototypes for innovative game projects.

## DOORS

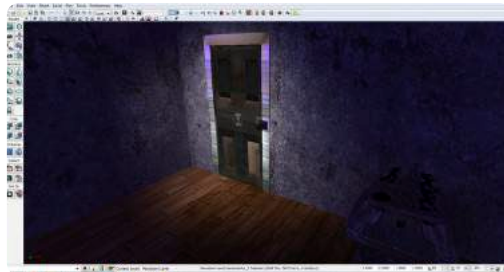

### The Project

*Doors* is a mobile game filled with mystery, mild horror, fear themes, and adventure. Best results occur on a tablet device such as an iPad. The game uses touch-based navigation and intuitive controls with an extremely minimal Heads up Display (HUD). The game uses an inventory system and visual clues leading players to puzzles that require solving in order to further their progress in the game, or gather puzzle pieces in order to properly solve other puzzles in the same room.

The prototype showcases controls, the setting, the story’s beginning, and the basic puzzle design of the first room. The prototype’s setting and layout is built with the Unreal Development Kit and the controls are all done using visual scripting in Kismet and Matinee.

### The Next Phase of Student Innovation

The prototype is complete and design for Level II is in progress. The project’s eventual goal is to distribute for widespread tablet use.



## aViDo Dog Collar

Bluetooth technology has gone to the dogs. That’s because Taylor Zuppan takes this technology to the next level of innovation with his SIP, the aViDo dog collar. Taylor has developed a light weight, small, highly water resistant convenient and customizable way to interact, communicate and train dogs, cats and other pets, especially those who are deaf and blind.

He is addressing real-world issues related to current vibrating dog collars that are heavy, inconvenient and have limited functionality.

Resolving these issues, his collar receives commands via a Bluetooth enabled device, such as a phone or the new Bluetooth watches.

As a Network Security major, Taylor’s SIP demonstrates his degree’s connection to UAT’s Artificial Life Programming and Robotics and Embedded Systems degree programs.

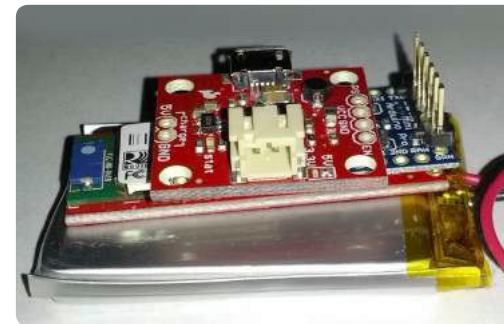

Designated as a Center for Academic Excellence in Information Systems Security Education, UAT offers this cyber security degree to provide the advanced industry-standard tools and skill development necessary to propel information network technology initiatives and ensure success in the network security field.

### The Project

Weighing a mere 2.5 ounces, the aViDo collar is activated and controlled remotely by an Android device via Bluetooth. The application hosted on the Android device is one-of-a-kind, with four unique commands that can be customized. Technology includes the Arduino Pro Mini, a Bluetooth Mate Gold Bluetooth module, an FTDI Breakout Board for programming and command customization, a 1000mAh Lithium Polymer battery, and a Lithium Polymer charger and 5v step-up board (since LiPo batteries output at 3.7V and 5V was needed for the Bluetooth module).

### The Next Phase of Student Innovation

The project is completed and functioning. Taylor would like to continue to refine the collar’s compact size and increase the water-resistant capabilities.



# INNOVATING THE FUTURE

BREAKING NEWS ON UAT STUDENT PROJECTS IN GAME DESIGN THAT ARE INNOVATING TECHNOLOGY.



Game Design

# INNOVATING THE FUTURE

BREAKING NEWS ON UAT STUDENT PROJECTS IN DIGITAL MEDIA THAT ARE INNOVATING TECHNOLOGY.

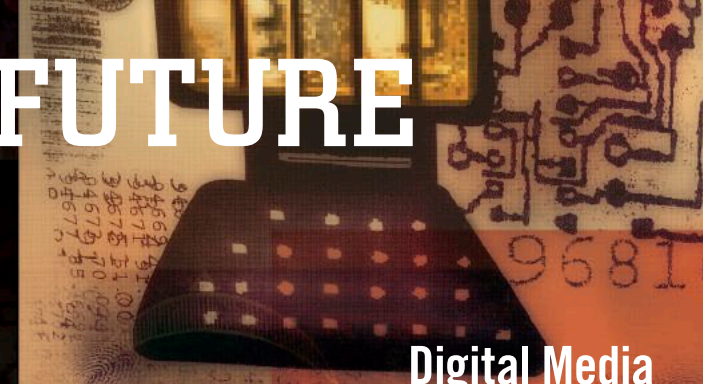

Digital Media

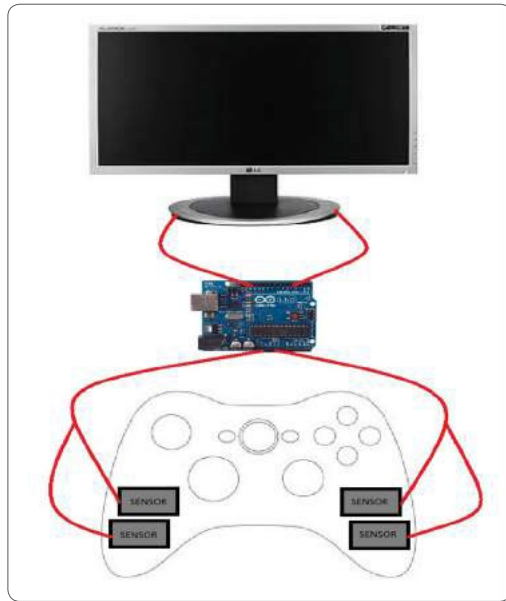

## OPERATION: Resistance

As exciting as they can be, games by design are generally stagnant. They convey an experience to the user, but the boundaries of that experience are determined long before the user enters the picture, and doesn't change when the user stops playing. Game Design major Shane Stansell is creating a modified game controller as his SIP because he envisions game play as different for every player every time. Operation: Resistance is designed to use biometric feedback to dynamically change game play in real time. With this innovation, Shane wants to provide a game experience that adapts to the specific needs of each player, without the requirement to play a certain game for a certain mood or predetermined content on a given day.

Game Design students focus on the design principles, skills and techniques required to create mechanics, and design documents and functioning prototypes for innovative game projects.

### The Project

Operation: Resistance's unique game mechanic will alter the player's experience by increasing difficulty, changing speed, etc.

A player's galvanic response actually manipulates game play. Using an Arduino Uno, sensors are placed into a game controller and on the player's skin to measure the electrical resistance of a player, much like the way a polygraph detects biometric changes. A series of four mini games also is being developed, each one using the input in unique ways. For example, a 2D side scrolling platform game uses the input to determine run speed of the character. Another example is a spacial reasoning game, like Tetris, where the speed that the blocks fall is controlled by the input values.

### The Next Phase of Student Innovation

The research phase is complete, and construction of the game controller with sensors currently is in process. The code is open source, so implementation looks promising.



## COOKING Fiesta

When you create a new game, it's impressive. When you innovate a new way to play a game that makes it more fun for everyone, that's a game changer.

Digital Media major Elvin Natal combined his love for cooking and playing cards with his passion for technology in the card game Cooking Fiesta and his unique innovation, the "Chef's Hidden Arsenal" game mechanic.

UAT's Digital Media degree provides the aesthetic, critical and technical framework for success in contemporary art and design practice. This highly respected media arts degree offers a diverse curriculum emphasizing aesthetic sensibility, programming literacy, creative expression and technical problem solving in media communication and digital media management.

### The Project

In this card game, designed for three to eight players age 10+, each player becomes a chef in a cooking competition fighting for ingredients and recipes represented in cards. The ultimate goal is to complete as many recipes as you can. The more recipes you complete, the more stars you receive, and the most stars wins the game.

The Chef's Hidden Arsenal is a game mechanic used to help players who are at risk for losing get back into the game. When a "chef" reaches below a certain level, the player can draw cards from the Arsenal deck, which allows all "chefs" to continue "fighting" and spawns more dynamic game play. This concept can be applied to any game.

### The Next Phase of Student Innovation

The project is complete with the first playable prototype game ready in its physical form. In the future, Elvin is considering expanding the game with more cards or even developing a mobile app form. He might initiate Kickstarter to help support further game development.





# INNOVATING THE FUTURE

BREAKING NEWS ON UAT STUDENT PROJECTS IN GAME PROGRAMMING THAT ARE INNOVATING TECHNOLOGY.



Game Programming

# INNOVATING THE FUTURE

BREAKING NEWS ON UAT STUDENT PROJECTS IN NETWORK SECURITY THAT ARE INNOVATING TECHNOLOGY.



Network Security



## VOX Render

Chances are, your video games are not all they could be. That's because video game graphics today suffer from a number of innate bottlenecks and shortcomings within the polygonal rasterization pipeline:

- > the lack of smooth level of detail transition
- > the non-linear scaling of performance with hardware power, and
- > the limits to how many triangles you can draw per frame

Game Programming major Daniel Strayer designed his SIP, VoxRender, to solve these real-world problems and many more.

UAT's Game Programming degree prepares students to develop a broad skill set, and become comfortable with many platforms and languages. Video game programmers develop games for web, console, PC and mobile devices.

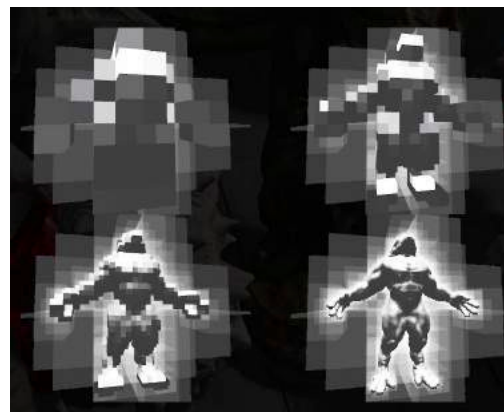

### The Project

VoxRender is a real-time rendering system for use in videogames with virtual reality, simulation visualization, and anything else that once required the use of polygonal rendering methods. VoxRender makes it easier for artists to develop 3D models as they will not have to create level-of-detail models nor will they have to create any kind of texture coordinate mappings.

The goal of the VoxRender system is to open up videogame graphics rendering to new possibilities and to surpass the traditional polygonal pipelines limitations and bottlenecks.

VoxRender is currently compatible with most Windows desktop computers with an NVIDIA GeForce graphics card of compute capability 2.0 or higher (480 and up).

### The Next Phase of Student Innovation

VoxRender is complete, proving to be efficient and powerful. Daniel plans to continue to refine the functionality and release an SDK for use within other game engines. Depending on the market, and possible demand for such technology, he will license the technology. One of Daniel's goals for the future is to use a device like the XBox Kinect peripheral to scan real world objects into virtual space by way of converting a surface sampled point cloud into the VoxRender format.

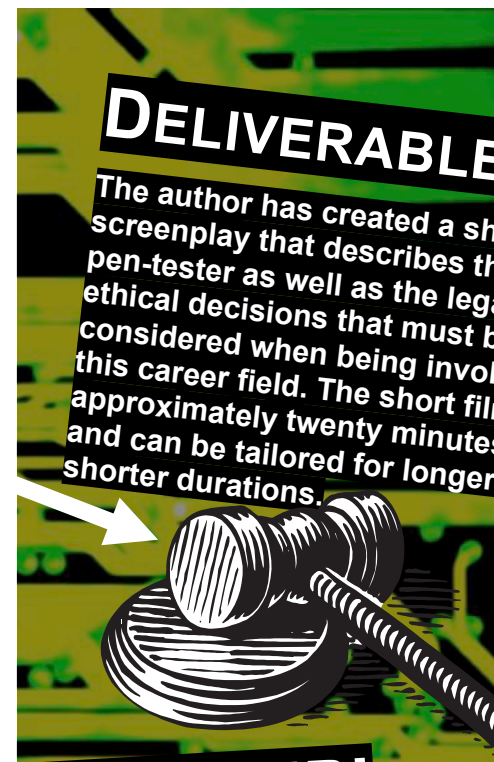

## PEN Tester

Want the inside scoop on penetration testing in the Network Security field? You'll be hard pressed to find it when you "Google" or search any website. This is unfortunate because the real-world experiences of others are uniquely powerful in helping prospective Network Security students learn more about the field—penetration testing, specifically—before deciding if it's a right fit.

Network Security major Micah Vorst offers a solution: the Pen Test Trailer, a script for a short film designed to highlight the experiences of pen testers currently working in the field to help prospective students understand the technical details as well as the legal, ethical and moral pressures that one faces in this career field.

Designated as a Center for Academic Excellence in Information Systems Security Education, UAT offers this cyber security degree to provide the advanced industry-standard tools and skill development necessary to propel information network technology initiatives and ensure success in the network security field.

### The Project

The fascinating, challenging real-life world of pen testing is captured in the 13-page script that, when made into a short film one day, can be posted on UAT's website for viewing by prospective Network Security students. The script features real-world scenarios, complete with narration, that address the legal and moral decisions professional pen testers face in the field every day, as well as their success stories.

### The Next Phase of Student Innovation

The project is complete. The final document is a hard copy that's available to anyone interested in producing the short film as a future SIP project.



# INNOVATING THE FUTURE

BREAKING NEWS ON UAT STUDENT PROJECTS IN HUMAN COMPUTER INTERACTION THAT ARE INNOVATING TECHNOLOGY.



Human-Computer Interaction

# INNOVATING THE FUTURE

BREAKING NEWS ON UAT STUDENT PROJECTS IN GAME DESIGN THAT ARE INNOVATING TECHNOLOGY.



Game Design



## MY MUSIC Mosaic

Music + Technology = the power to improve lives. Molly Satterfield's SIP: My Learning Mosaic, does just that. Created for the All Greater Good Foundation and the San Diego Center for Children, My Music Mosaic uses music as a tool to help children and teenagers in difficult circumstances communicate by visual expression.

Molly, a Human-Computer Interaction major, worked with a team of students including Jaylyn Dawson (Human-Computer Interaction and Technology Product Design), Joshua Vargas (Technology Product Design); and Amanda McIntyre, (Advancing Computer Science) with guidance from Professor Ryan Meuth and Professor Vesna Dragojlov.

UAT's Human-Computer Interaction degree is based on the interfaces and interactions between electronic devices and the users that rely upon them.

### The Project

My Music Mosaic takes input from a musical keyboard and represents them with different colored brushstrokes to demonstrate the music being played in a digital painting. Each instrument has its own brushstroke and each note is a color. Making many color palettes available help the users pick the colors that best fit their mood and the type of song. The longer the note; the longer the brushstroke. The more forceful the note is hit, the bigger it is. Splats represent quick notes. The result is a digital painting with different colored brushstrokes that is uniquely expressive and therapeutic.

### The Next Phase of Student Innovation

Although Molly and her team have presented the first version of the project to the Foundation, there are plans for further development. They hope to create more user customization, more brushes/splats to visualize the different instruments on the keyboard, and fix any technical bugs that may arise.



## ULTRA Sketch

When can a collection of video games not only be social and interactive but also contribute to tourism and commerce in a major Arizona city? When it is UltraSketch; a unique game project pitched to and commissioned by the City of Tempe as an innovative way to encourage exploration of the city's landmarks, and developed in UAT's Experimental Entertainment Technologies class.

Game Programming graduate Gregory "Raj" James serves as lead programmer on a team that also included UAT's Robotic and Embedded Systems students who created the eight-foot-tall giant "Etch-A-Sketch" machine. Other team members integral in the project's success have majors in Game Design, Game Art and Animation, and Human-Computer Interaction.

UAT's Game Programming degree prepares students to develop a broad skill set, and become comfortable with many platforms and languages. Video game programmers develop games for web, console, PC and mobile devices.



### The Project

The 92-inch by 95-inch UltraSketch is made out of plywood with paint bucket knobs. A rear projector displays the game onto the screen and is driven by a computer. Key components of the project include "Free Sketch," "Connect-the-Dots" and "Tempe" interactive game modes. The Tempe mode selects a point randomly from a database and creates a map to that destination from the current location. Players draw out the route to the destination and then are sent to the location to take pictures and upload them to the website/Facebook.

### The Next Phase of Student Innovation

UltraSketch is making the rounds at various locations in Tempe to demonstrate its capabilities and give people the chance to play the games. "We're really excited, but at the same time there's still a lot of polish that is needed," Greg said in a Phoenix Business Journal article. "It's kind of like its own new console, and with more games planned by students it will feature a library of games."



# INNOVATING THE FUTURE

BREAKING NEWS ON UAT STUDENT PROJECTS IN NETWORK SECURITY THAT ARE INNOVATING TECHNOLOGY.

Network Security

# INNOVATING THE FUTURE

BREAKING NEWS ON UAT STUDENT PROJECTS IN GAME PROGRAMMING THAT ARE INNOVATING TECHNOLOGY.

Game Programming

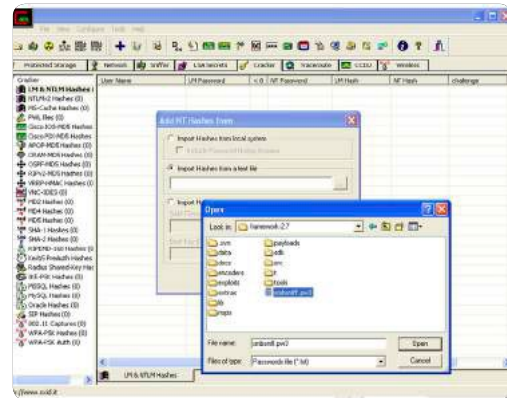

## PROJECT Icarus

Developed by Network Security major Jason Caval, Project Icarus is a Windows 7 Virtual Hard Drive Penetration Testing Image that works with both Virtual Box and VMWare. The project is innovative with its creative way to set up new testing tools and programs with ease.

Designated as a Center for Academic Excellence in Information Systems Security Education, UAT offers the Network Security degree to provide the advanced industry-standard tools and skill development necessary to propel information network technology initiatives and ensure success in the cyber security field.

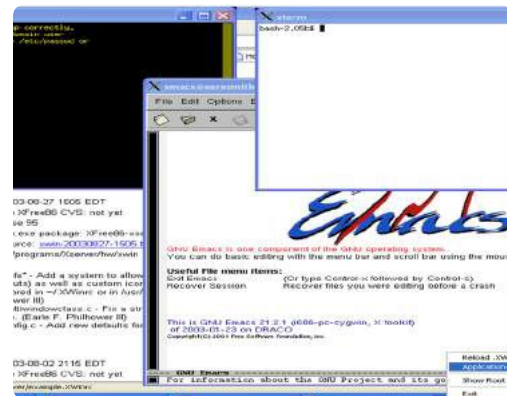

## The Project

Project Icarus is scalable with different hard drive sizes and has a base snap shot that can be reused as needed. It is useful for writing up post penetration testing reports with Microsoft Office.

Preconfigured tools include:

- > Metasploit
- > Password cracking
- > Scanning networks
- > Finding vulnerabilities

## The Next Phase of Student Innovation

Future updates include:

- > Cygwin for a Linux run time environment
- > Ruby, Python and other language support for scripting
- > Use of the virtual machine inside a virtual machine to test at the same time

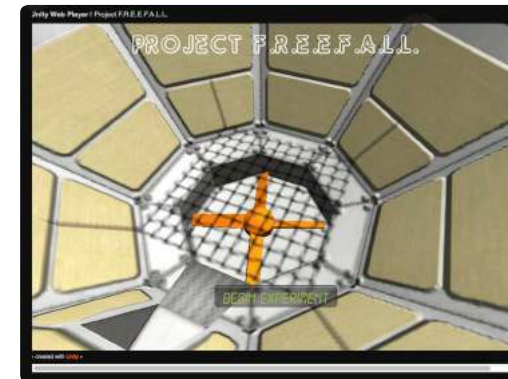

## PROJECT F.R.E.E.F.A.L.L.

At commencement, UAT spring 2013 graduates not only felt the thrill of completing an elite advancing technology degree but also the thrill of free falling, thanks to Game Programming major Maureen Perzan's SIP Project F.R.E.E.F.A.L.L. Utilizing both robotics and game development programs, she and her team created an interactive game that gave graduates control of an avatar free falling downward at a rapid pace.

UAT's Game Programming degree prepares students to develop a broad skill set, and become comfortable with many platforms and languages. Video game programmers develop games for web, console, PC and mobile devices.

## The Project

Selected as the Tech Moment for UAT's spring 2013 commencement ceremony, Project F.R.E.E.F.A.L.L was developed as an interactive obstacle avoidance game played by UAT graduates, who worked on teams to control the movements in a freefall motion.

The innovation claim lies within the controls, which were handheld LED devices custom-made through UAT's embedded systems programming team led by Professor Dr. Ryan Meuth.

The game was played with roughly a hundred players, who were divided into four groups (one for each limb). Each player had a hand held controller that directed a single degree of movement. The movement for each limb was averaged out among the team and reflected in the avatar's overall ability to avoid obstacles during the free fall.

## The Next Phase of Student Innovation

The project was completed and presented at UAT's Commencement ceremonies on May 17. Because it was designed specifically as the commencement's Tech Moment, there are no plans to continue the development of this game, although the LED devices with their updated software may be used for future Tech Moments. Readers can play the build at Maureen or Daniel's portfolio sites

(<http://www.moperzan.com/project-freefall.html> and <http://www.danperzan.com/games.html>, respectively).





## info

2625 W. Baseline Rd. > Tempe, AZ 85283  
Phone 877.UAT.GEEK > Fax 602.383.8222

[www.uat.edu](http://www.uat.edu)